

RADIO WORLD

REG. U.S. PAT. OFF.

SHORT WAVES IMPEL CONSTANT ALERTNESS



25c
PER COPY

Whether one listens on 'phones to a one-tube super-regenerator with single-turn loop, or uses a 22-tube, 60-watt receiver for bringing in short waves, there are certain vagaries that must be appreciated. These are set forth in the article beginning on page 8.



CAPACITORS
for every
ENGINEERING REQUIREMENT

SPECIALIZATION . . . specialization in the manufacture of quality condensers, exclusively . . . which has inspired the CORNELL-DUBILIER organization throughout its twenty-seven years of achievement—has made the dream of yesterday the accomplished fact of today.

Broadcasting stations; United States Navy, Army, Signal Corps, and other governmental divisions; telephone companies; manufacturers of receivers, transceivers, transceptors and transmitters; engineers, amateurs and servicemen—the CORNELL-DUBILIER organization supplies the condenser needs of all and does so with a performance plus!

No more expensive shopping . . . no more testing . . . and no more experimentation. C-D engineers have a design for every requirement.

PAPER · MICA · DYKANOL
WET AND DRY ELECTROLYTICS

FOR DEPENDABLE PERFORMANCE
Standardize on C-D CAPACITORS

WORLD'S LARGEST EXCLUSIVE MANUFACTURER
OF CAPACITORS FOR MORE THAN 27 YEARS.

*Complete descriptive literature free
on request.*

CORNELL-DUBILIER CORPORATION
SOUTH PLAINFIELD, NEW JERSEY

CORNELL-DUBILIER



HOW A FREE LESSON STARTED BILL ON THE WAY TO A GOOD RADIO JOB

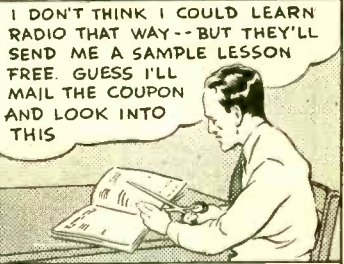

Yes, I will send my First Lesson FREE to show how easy it is to TRAIN AT HOME FOR A GOOD RADIO JOB

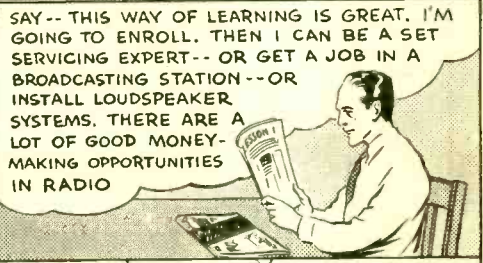

J. E. SMITH, President National Radio Institute

Do you want to make more money? I'm so sure that I can train you to become in your spare time for a good Radio Job that I'll send you a sample lesson absolutely FREE. Examine it, read it, see for yourself how easy it is to understand even if you've never had any technical experience or training.

how to conduct experiments and build circuits which illustrate important Radio principles. My Training gives you practical Radio Experience while learning.

Get My Lesson and 64-Page Book FREE -- Mail Coupon

In addition to my Sample Lesson, I will send you my 64-page Book, "Rich Rewards in Radio." Both are free to any fellow over 16 years old. My book describes Radio's spare time and full time opportunities and those coming in Television; tells about my Training in Radio and Television; tells about my Money Back Agreement; shows you actual letters from men I have trained, telling what they are doing and earning. Find out what Radio offers YOU! MAIL THE COUPON in an envelope, or paste it on a penny postcard--NOW!

J. E. SMITH, President National Radio Institute, Dept. 7FM4 Washington, D. C.



Many Radio Experts Make \$30, \$50, \$75 a Week

Radio broadcasting stations employ engineers, operators, station managers, and pay up to \$5,000 a year. Spare time Radio set servicing pays as much as \$200 to \$500 a year. Full time Radio servicing jobs pay as much as \$30, \$50, \$75 a week. Many Radio Experts own and operate their own full time or part time Radio sales and service businesses. Radio manufacturers and jobbers employ testers, inspectors, foremen, engineers, servicemen, paying up to \$8,000 a year. Radio operators on ships get good pay and see the world besides. Automobile, police, aviation, commercial Radio, and loud speaker systems offer good opportunities now and for the future. Television promises many good jobs soon. Men I have trained are holding good jobs in all these branches of Radio.

Many Make \$5, \$10, \$15 a Week Extra in Spare Time While Learning

Practically every neighborhood needs a good spare time serviceman. The day you enroll I start sending you Extra Money Job Sheets. They show you how to do Radio Repair jobs that you can cash in on quickly. Throughout your training I send you plans and ideas that have made good spare time money--from \$200 to \$500 a year--for hundreds of fellows. I show you special Radio equipment and send you

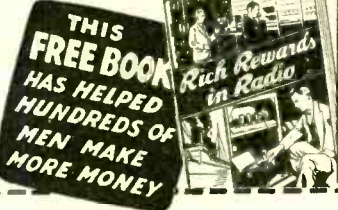

MAIL THIS NOW

J. E. SMITH, President National Radio Institute, Dept. 7FM4, Washington, D. C.

Dear Mr. Smith: Without obligating me, send the sample lesson and your book which tells about the spare time and full time opportunities in Radio and explains your 50-50 method of training men at home in spare time to become Radio Experts. (Please Write Plainly.)

NAME..... AGE.....

ADDRESS

CITY..... STATE..... 14X-1

SAY, JIM, I'M 'PHONING YOU BIG NEWS! GREAT!
 SUPERIOR HAS A 100 KC TO 100 MC THAT'S
 SIGNAL GENERATOR with JUST WHAT
 CALIBRATED AUDIO I NEED! I'LL
 FREQUENCIES GET ONE
 AT ONLY \$14.40 RIGHT
 AWAY!



Precision, Beauty, Price

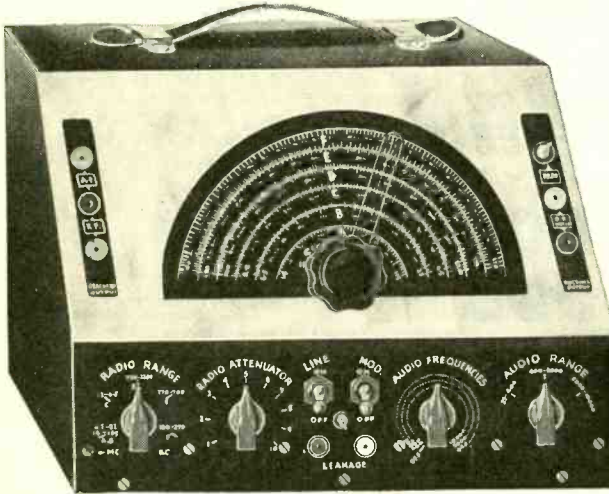

Characterize Our

**De Luxe
 Superior
 GENEMETER**

\$14.40

Complete with
 Four Tubes

FEATURES:

1. Direct reading in frequencies, 100 kc—22 mc, in five bands, all fundamentals, by front-panel switching. Ultra band by harmonics to 105 mc, also direct-reading.
2. Direct reading in frequencies, 25—10,000 cycles, in three bands, all fundamentals, by front-panel switching.
3. R.F. and A.F. outputs independently obtainable alone, or with A.F. (any frequency) modulating R.F.
4. Output meter for connection across primary of receivers' output transformer for peaking with modulation "on."
5. R.F. is subject to attenuation, and oscillation leakage is minimum.
6. Condenser and other leakage tested, to 100 megohms.
7. Main dial protracted on 7/8" diameter, used full size, with precision pointer (no parallax), and 4-to-1 vernier planetary drive.
8. All services on 90-130 volts a.c. or d.c.

Shipping weight, 10 lbs.

A Thing of Beauty and a Joy Forever Is Our New Genemeter, an All-Wave Signal Generator, with Variable Audio. Its Front Panel Slopes at the Pitch of a Cash Register. And Servicemen Equipped with Our New Instrument Will Ring the Bell Often and Every Time!

ALL the refinements that you would demand of a costly Signal Generator are embodied in our new GENEMETER. First in importance is accuracy. The GENEMETER has it— $\frac{1}{2}\%$ on intermediate and broadcast bands, 2% on short waves. Modulation must be present or absent by switching. It is. And, besides, the audio is variable. Direct reading in frequencies, it permits response measurements of amplifiers.

Beauty? The picture tells the story. Output meter? That is included, too. Even condenser and other leakage may be tested. All frequencies, radio and audio, are direct-reading. The large dial is 4-to-1 vernier, with costly planetary drive.

Outstanding is the word for GENEMETER.

ORDER DIRECT FROM

SUPERIOR INSTRUMENTS CO. 136 Liberty St., New York, N. Y.
 Dept. RW 6

Send for our free Catalogue PV, in colors, describing our complete line.

INCREDIBLE, What the Allmeter Does!

Volt - Ohm - Ammeter
PLUS

A.C. Volts - A.C. Currents
Capacities - Very Low Ohms
Henries - Decibels
Vacuum-Tube Voltmeter

**21 INSTRUMENTS
in One
at Only \$10.40**

1—A-C Currents, 15-150-750 ma. This extremely valuable service is practically never afforded by multi-test instruments. Instruments, 3.

2—A-C Volts, 15-150-750 volts. Affords also output meter service. Instruments, 3.

3—CAPACITY, .01-50 mfd., all condensers, including electrolytics. Instruments, 1.

4—5-1,000 Henries, coil loaded or not. Instruments, 1.



No. Z

5—LOW ohms, .03-500 ohms. Extremely valuable.

6—HIGH ohms, to 0.5 meg., covering all practical values. Instruments, 1.

7—D-C Volts, 15-150-750 volts. Simplified scale uses same calibration as for a.c. Instruments, 3.

8—D-C Currents, 15-150-750 ma. The same scale simplification. Instruments, 3.

9—Decibels, -12 to +10, also foregoing plus 20. Instruments, 2.

10—Vacuum - tube voltmeter, 0-15-150-750 volts. Instruments, 3.

11—Short tester, including condensers. Instruments, 1.

1,000 ohms per volt, d'Arsonval movement, direct reading.



No. Y

The Superior Tube Tester

Price 1s only.. **\$10.40**

Shipping weight, 10 lbs.

Dependable Tube Tester

* FEATURES *

- ★ Tests all 4, 5, 6, 7s-7L and octal base tubes.
- ★ Tests all Diodes, Triodes, Pentodes and Tetrode receiving tubes, as well as many transmitting types.
- ★ Will check diode, triode and pentode sections of composite tubes separately.
- ★ Separate Neon Test for leakage or shorts between elements.
- ★ English reading meter, with "BAD-?-GOOD" scale. Minimum number of adjustments, without impairing efficiency or accuracy of test.
- ★ Rugged, foolproof construction. Built for a lifetime of use.
- ★ Attractively designed front panel. Metal case.
- ★ Compact and lightweight. Ideal for service laboratory or field servicing.
- ★ Supplied with complete instructions and tabular data for every known receiving type of tube, including many transmitting types.

Order Direct From

SUPERIOR INSTRUMENTS COMPANY

Dept. W-5 136 Liberty Street, New York, N. Y.

Send for our free Catalogue PV, in colors, describing our complete line.

RADIO WORLD

Sixteenth Year

ROLAND BURKE HENNESSY
Editor

H. J. BERNARD
Managing Editor

HERBERT E. HAYDEN
Advertising Manager

Table of Contents for JUNE, 1937

Short Waves in Brief 8 <i>Installing and Operating Set; Tuning in Chosen Waves</i>	What Is Vital for Servicing 31 By Joseph T. Bernsley <i>Chief Engineer, Superior Instru- ments Co.,</i>
Off the Beaten Track 14 <i>Personality in Servicing</i> By H. J. Bernard	An Electronic Voltmeter 34 <i>Built Around the 6E5</i> By E. L. Deeter
What Made P.A. Big 18 <i>The Little Things Counted</i> By M. N. Beitman	Unusual Indicator Tube, 6T5 ... 39 <i>New Device Changes Light Di- ameter</i>
Voltages Across Elements 20 <i>Some Tube Dilemmas Explained</i> By Emil Buchwald	Frequency Extension 40 <i>New Aspect of Using Harmonics Without Confusion</i>
Making Supers Track 22 <i>Easy Methods, Little Apparatus</i> By R. K. Wheeler	Matching R-F Impedances 42 <i>Uniform Transmission Lines</i> By J. E. Anderson
Adjusting I.F. to Oscillator Coil 24 <i>Another Tracking Method</i>	FORUM 47
The Trend of Radio Servicing .. 26 By M. M. Brisbin and W. J. Zaun <i>RCA Manufacturing Company, Inc.</i>	How to Use Meters 48 <i>D-C Instruments Discussed</i>
Servicing Job or Profession?.. 28 By Leland S. Hicks <i>Thordarson Electric Mfg. Co.</i>	New Products 51 <i>Eleven Pages of Latest Trade News</i>
Business and Sales Next 30 By Tobe Deutschmann	At Your Service 60 <i>Radio University—Questions and Answers</i>

Vol. XXX, June, 1937. No. 3. Whole No. 705. RADIO WORLD, published monthly by Hennessy Radio Publications Corporation, 145 West 45th Street, New York, N. Y. Editorial and executive offices, 145 West 45th Street, New York, N. Y. Executives of RADIO WORLD: Roland Burke Hennessy, editor and business manager; H. J. Bernard, managing editor; Herbert E. Hayden, advertising manager. Officers of corporation: Roland Burke Hennessy, president-treasurer; Roland Burke Hennessy, Jr., vice-president, H. J. Bernard, secretary. Entered as second-class matter March, 1922, at the Post Office at New York, N. Y., under Act of March 3rd, 1879.

SUBSCRIPTION RATE

Price 25 cents per copy. Subscription \$2.50 per year (12 issues); \$1.25 per six months (6 issues); postpaid in United States and Possessions; \$3.00 per year, \$1.50 per six months, postpaid in all other countries. Remittance for foreign subscription should be by International money-order (postal or express) or draft against or discountable at New York bank.

RADIO WORLD is distributed by the American News Company and its Branches



"I'll show you how to get the jobs that other Radio men can't handle"

MAKE \$40-\$60 a WEEK New Kind of Radio Training

with this

It Actually Sets You Up In Business!

Now there's a new kind of Radio training every man should know about if he wants to get in on the money end of the Radio industry. Men taking my training right now are actually earning \$10, \$15, \$20 a week and more in spare time—while they learn. Men who are graduated are holding down jobs paying \$60 a week and up.

Make More Money Quick

My course is arranged so that you get practical lessons right at the start. Quickly, you are able to begin servicing sets. Useful, simple job sheets show you every step to take. And you have the equipment to handle these jobs properly. Time and time again my students write in to tell me they are handling jobs other Radio men couldn't handle. That's because my easy men understand lessons and professional equipment make you a real Radio expert.

No Experience Needed

Old-timers and new-comers are taking this new kind of training and making real money in Radio. If you are a Radio man now, you know now is the time to get extra training and bigger pay. If you are just about to enter Radio, now is the time to start taking this thorough, easily-learned course. Everything is clear. Everything practical. You learn business methods, gain self-confidence, get the satisfaction that nothing but quick cash in the pocket can give you.

Get the Facts

Your future in Radio can be rich and happy if you get started on the right track, get the kind of instruction that puts you ahead of others from the start. My new book, entitled "MORE MONEY IN RADIO" tells about Radio's spare-time and full-time opportunities. It tells you about my unusual new type of practical Radio training, shows you letters from men who have found success this way, shows how YOU can do the same. Send for this book today and get the facts. Act now! Fill in and mail this coupon at the right.

Big Professional Outfit Sent

You learn at home, in your spare time, you train on real Radio parts, with real professional tools and implements. I send them to you as part of your course. This big professional outfit is practically an entire Radio shop in itself.

SPRAYBERRY'S MASTER SERVICE COURSE FOR SERVICEMEN ONLY

A new 45 lesson Course on Radio Service work. Describes the actual how to do it way. Practical, modern and easy to understand. Every serviceman needs this Special Service Course. Nothing like it in print. Represents years and years of experience at actual Radio Service work.

SEND TODAY FOR CATALOG. FILL IN
COUPON AT RIGHT—CATALOG DESCRIBES
BOTH COURSES.

Terms as low as \$3 per month.



EDWIN A. GAMMON, Auburn, Maine, writes: "Your course is so thoroughly good and practical that it is hard to pick out one part that is better than any other. Due to the knowledge I have gotten from it I have been deluged with work for the last month. I have been deluged with work which had been achieving good results with radios which had been unsuccessfully tackled by other service men. You deserve all the credit, and I can tell you how much I appreciate your course."



WALTER DAVIS, Baltimore, Md., writes: "Thanks to the Sprayberry Practical Course (for which I would not take anything or any price). I am now making on an average of from \$10 to \$25 per week in spare time work, and if this keeps up I may go in for full time radio servicing and sales. Thank you again."



NOW SEND FOR FREE BOOK!

My free book has started hundreds of men on the road to success in Radio and happiness in life. It's crammed with facts you can't afford to miss—filled with TRUE STORIES of men that I put into Radio. Get this book and read it. If others can succeed in Radio, so can you—it's all in getting started right. So get the right start TODAY—mail this coupon for YOUR copy of this great FREE BOOK!



MAIL COUPON TO WASHINGTON TODAY

SPRAYBERRY ACADEMY OF RADIO,
F. L. Sprayberry, President,
Office No. 35-G, University Place, N. W.,
Washington, D. C.

Please send me, without obligation, "More Money in Radio" and complete facts about your new type of training.

NAME

ADDRESS

CITY STATE.....

(Paste this coupon on a penny postcard and mail TODAY.)

...most faithful reproduction. They
serve, secondarily, for reducing the troublesome
(Continued on following page)

(Continued from preceding page)
 tion, its full possibilities can be realized only
 by those familiar with the general charac-
 istics of transmission

able to the short-wave listener for out-
 tion of the day

OFF

By H. J. Bernard

The Beaten Track

To Do a Good Turn to Others and Yourself

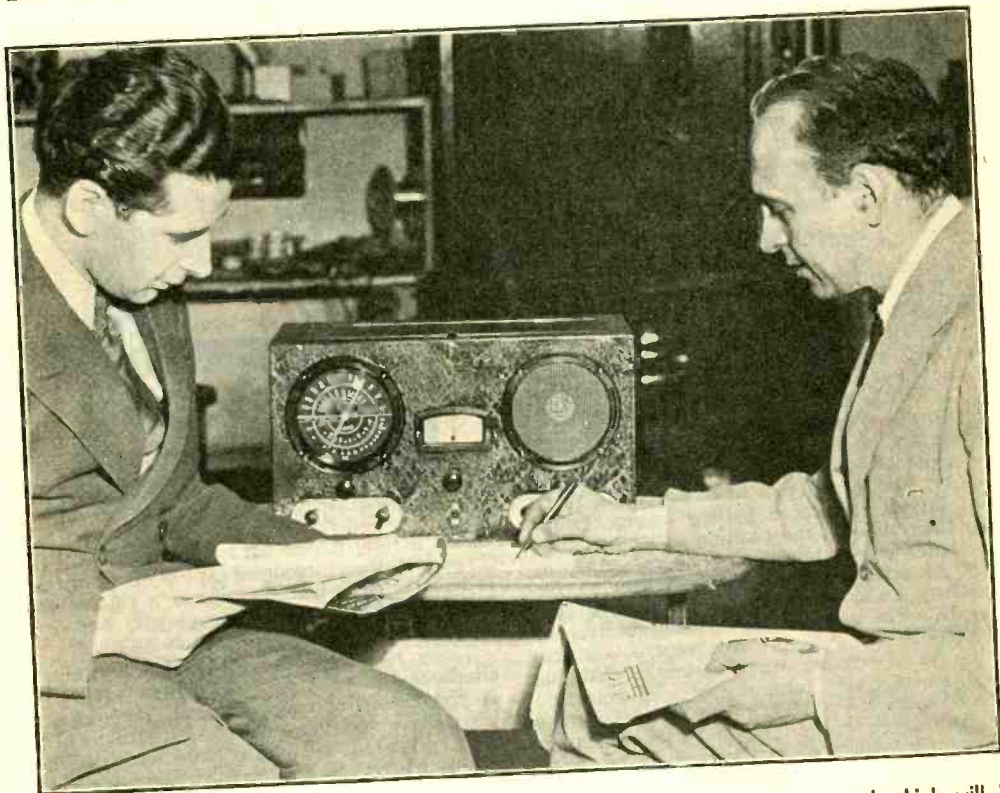

A test of versatility that servicemen may recommend to their brighter customers, and which will be appreciated as a game that takes intellect, is to combine radio listening with other listening and indeed even additional operations. Above, Max Steir is shown reading from a radio magazine to Bradford Guy Hollingsworth, who is (a) listening to a radio commentator; (b), reading from a second magazine, and (c) writing on an entirely different topic, while (d) hearing Mr. Steir's elocution, all at the same time.

EVERYONE engaged in servicing has the ambition to be successful, but that ambition may be passive and therefore never gratified, or though it may be active it may still foreclose its own attainment because a factor seldom mentioned to servicemen enters. It has nothing much to do with the stock requirements of education, experience and instrumentation, all of which are important, but it concerns rather the social graces. Imagine a man working often in denim apron or even overalls being endowed with social graces!

And to what purpose must he rise to the level of the neighborhood swells if the occasion demands? Because the customers then have a higher regard for the serviceman, and the scope, extent and success of his business depend as much on customer regard as on anything else. One might safely say that all preparation, all education, all advertising, all equipment and all goodwill have only the single, overmastering objective—favorably impressing the customer.

It is strange that the cultural side of ser-

ving is so greatly neglected by the published authorities. Is it not true that persons of lesser capabilities often outstrip their intellectual superiors in business because of a winning personality?

BEING PERSONABLE PAYS

Politeness has been defined as an interested and patient consideration for the privileges of others. Personality is always in the same direction as politeness. The other fellow likes you because of your agreeable nature and your interest in his affairs. Both imply self-sacrifice. You put yourself last—the other fellow's affairs come first! When a man realizes you are constantly thinking of him, he begins to think of you, and often his thoughts will run in your direction in a manner in no way injurious to your economic wellbeing.

If possessing all the background and experience to equip one for excellent service work were enough, then the individuals constituting the radio servicing industry would be far more successful than they are. Especially at this time of the year must many in the industry feel that they are not getting their full share of the material rewards, as the profits of Winter go to finance a slack Summer. And yet there are many, many servicemen who prosper in Summer, and who do even better than just that in Winter, and when you come to analyze their assets, tangible and intangible, the goods, wares and merchandise differ not much from those of competitors less favored in a business way, and so there must be something that enables those favored of the gods to ride along in envied ease! That something is personality. It is derived from a multitude of minute factors of conduct, it can't be defined any more than can electricity, but it is just as vibrant, just as pervading and just as real. It can't be laughed off and it can't be cried down.

KEEPING WIDELY POSTED

Servicing work consists of more than just fixing a set. Everyone should aspire to be a regular fellow, in the best sense of the phrase, and take an interest in the affairs of all those around him, including of course strangers. He must not have dancing before his eyes the apparition of riches derived from acting like someone he isn't. He does not have to be approachable and sociable as part of a scheme to enrich himself. He has to be sincere in his social purposes no less than in his business dealings. Being friendly and personable pays, but it is not sound to hold the pay as the objective.

An example of how radio servicing really requires a social and cultural side is afforded by a young repairman who made a sincere practice of keeping himself well-informed on radio affairs. Not only did he keep abreast of technical developments, and understood them far beyond the capabilities of some of his competitors, but he knew what programs were on the air, and when, and read up so diligently on the show business side of radio that the radio editor of the local newspaper frequently

called him up to verify the spelling of some singer's or announcer's name, or some other fact far removed from frequency modulators and volt-ohm-ammeters.

When a national women's club committee selected paragon radio programs, citing among others Rudy Vallee and Kate Smith, this serviceman memorized the list, and whenever he met persons socially, or in business, he would discuss the awards, and thus interest prospective customers in programs they perhaps had not been listening to regularly. More than that, he expended ten or twelve dollars three nights a week to telephone a long list of persons, a little while before one of the award programs were to go on the air. The recipients of this attention were amazed and delighted.

TOUGH ON LOWELL THOMAS

The telephoning having served its purpose, he then resorted to the mail, informing all whom he could thus reach within his imme-



If any of your customers have a child who shows a special aptness for dancing, encourage the parents to have the child dance to radio music. Such encouragement is deeply appreciated by parents and produces valuable goodwill.

diate locality, of the prize program on the air the night of the day the form letter was received. He signed each letter personally. There is no telling just how much good this welfare operation did him. Anyway, he buys a new car for family use each Spring, and this year's model is two jumps outside the lowest-price class.

Another serviceman, living nearly 3,000 miles distant from the first, but in the same sociable if not geographical atmosphere, devised a radio game. Anything desired was tuned in, say, Lowell Thomas. Then for a one minute sentences would be read to the player-listener while Mr. Thomas spoke. After Mr. Thomas signed off, the subject was asked to write down

(Continued on following page)

(Continued from preceding page)

what Mr. Thomas had said during that brief period, and what the person in the room had read aloud. Now, that seems hard, but isn't quite so, especially when one puts too much credence in the proverb that you can't do two things at once and do them well. You can. The question is, Will you?

He tried this game out when visiting customers, always springing it after he had demonstrated a set he had repaired. He left a lasting impression, also an idea that caught on. Soon

probably catch up with the brain trust. And customers, present and prospective, like it, and like Mr. Serviceman for it, too. He supplies stenographic transcripts of Mr. Thomas's talk as an incitement to the game.

All methods of encouraging the use of radio receivers are favorable to the service industry. While some unattractive programs are on the air occasionally, most of the others are good, and some of these others are splendid. It serves no purpose to go around knocking one's own source of livelihood—radio—no matter what

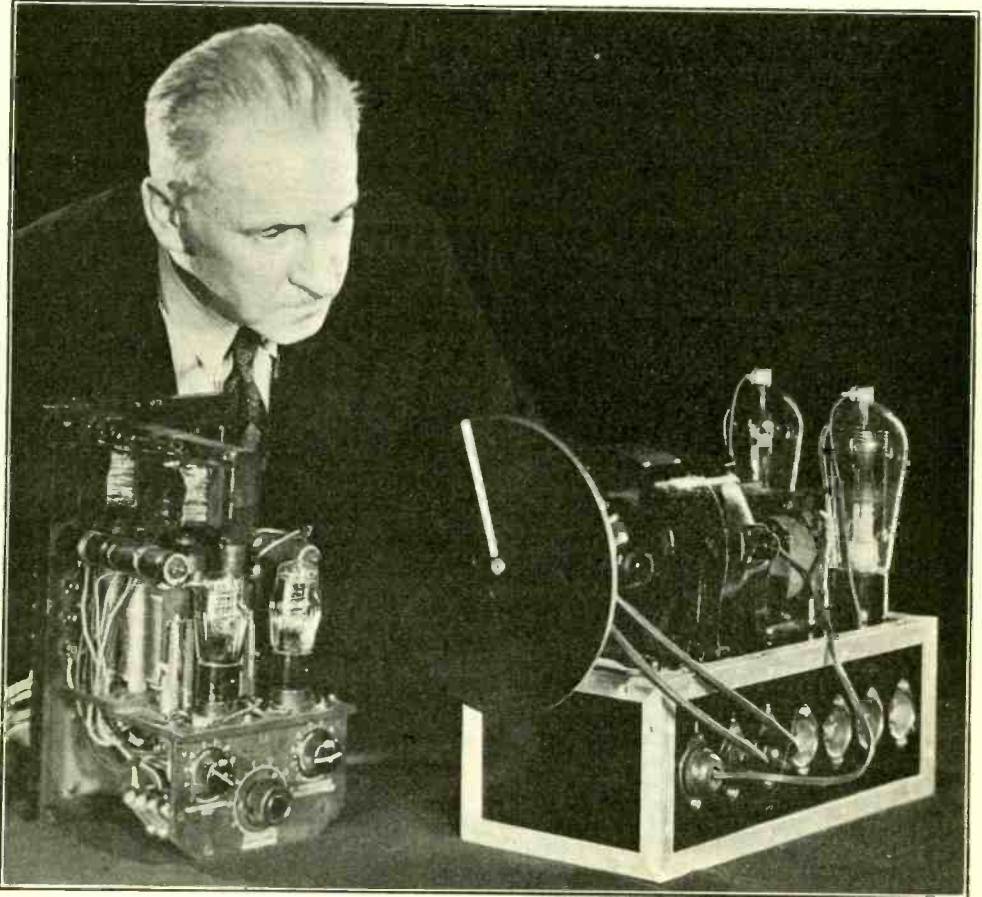

There is much work in electronics outside the receiver and transmitter fields. Vacuum tubes are used more and more in industry. The synchronizing units shown (one with stroboscope) automatically cut in more transformers as commercial power consumption requires.

scores of families were playing the game, and children liked it, too. Then he made return visits, adding to the difficulty of the game, until parents and even college students got interested. The stunt became this: listen to the commentator for one minute, also to someone reading from a magazine during the same period, write something out of your own head meanwhile, on a different topic than either of the others, and also read aloud from another magazine. The game is growing so fast it will

branch is being discussed. Stress the good aspects. Get persons to listen to the radio more often. Some day no doubt servicemen will cooperate with national advertisers who use coast-to-coast hookups, in encouraging listening to particular programs because these programs are outstanding. And with Radio voting in the offing, servicemen will grow in importance. So they should get a lot of experience now in social contacting, far beyond what they normally consider necessary.

Another serviceman shows especial interest in people's children, and by the way, he has a pair of fine little girls himself.

He happened to see a four-year-old girl dancing in the street. The girl had to stop because her music was wrested from her by the law. A policeman made the organ-grinder cease. A new forbidding ordinance had been enacted a week before. The organ-grinder did not hear, or did not want to hear, about it.

So the serviceman asked the girl where she lived, went up to see the parents, explained to them he thought that their daughter had very promising talent as a dancer, recounted the street incident, and suggested that the parents encourage the child to dance to radio music at home. That she has been doing for several months, meanwhile having begun to take lessons, and if she does not make her mark as a dancer, Mr. Serviceman will have missed his friendliest guess.

So fixing sets is not all. Neither is it all, on the technical side. Vacuum tubes are being used more and more in industry. One serviceman was smart enough to build up a counting device for a factory in his city, for which he received \$250. It used two photo-electric cells and an amplifier and rectifier, and any one well-grounded in vacuum tubes could make such an instrument. Another serviceman devised a staggered sign flasher relay, with filters, the whole costing less than normal filters would. Actually, a series of neon tubes of the quarter-watt size was used, the time constant of each one so arranged that the tubes "struck" at evenly-spaced intervals, and their currents controlled electro-magnets, so that a relay was instituted, a small device controlling a very large one.

This is the same principle as is used in many electrical instruments. Of course the problems of higher order of magnitude must be solved in laboratories to which power companies, railroads and the like naturally turn, but at least smaller operators will consider servicemen's

suggestions and often spend appreciable money on application of the ideas.

One can not hope as an individual to compete with Westinghouse but the principles used by Westinghouse can be understood and applied to profitable industrial purposes.

THE PHOTOGRAPH EXPLAINED

The illustration of the two devices, one with a stroboscope, is of vacuum-tube application to the control of powerful machinery, the relay in this instance being synchronous. Dr. Phillips Thomas, Westinghouse engineer, is demonstrating it. The device is particularly interesting not only as encouraging the wider use of vacuum tubes in industry, and thus the extension of business possibilities for servicemen, but also because considerable ingenuity as applied in the solution of a problem. Hence here is a clue: Talk to business men and factory executives about their production and control problems. You may be able to think up a solution, demonstrate it, and collect enough for a down payment on a new car!

The function of the Westinghouse vacuum-tube synchronizer is to connect automatically an auxiliary alternating-current generator into a power-line system already served by one or more generators, usually because the customer load has become too high for the normal number of generators to supply without such assistance.

To make such a connection without disagreeable or disastrous flickering of the station's generated voltage, the tie must be made when the incoming generator is putting out a voltage of substantially the same value, at the same frequency, and at the same phase, as the station output.

The demonstration shows the actual automatic connection of a small synchronous generator to the supply of current on the platform. The amount of advance action supplied by the vacuum tube relay is made visible by use of the stroboscope.

Thumbs Up and Down

CHARLIE G-MAN'S NO. 1

RADIO WORLD is No. 1 magazine with me.
CHARLES G. KAEHMS,
Room 1039, 65 Market St.,
San Francisco, Calif.

* * *

NO FEAR TOUCHING LIVE WIRE

Your publication is a live wire when it comes to modern advancement.

Go WESTLING,
1380 E. 28th St., Oakland, Calif.

HIS PERIODICAL HELPER

I find your magazine very interesting and quite often get numerous ideas from articles, which help me in business. Again, thanks.

GODFREY'S RADIO SERVICE,
184 - 8th Ave., New York City.

* * *

MAY BEST (NOT WEST)

Your May issue is about the best you have published, even though I considered each of the others very valuable in radio work.

R. COOPER BAILEY,
Virginia Electric and Power Co.,
Richmond, Virginia.

* * *

HAD TO BE GOOD

I have been buying RADIO WORLD magazine since it was a weekly, way back to about '27 or '28. For me to buy it for so many years it had to be good.

W. A. BRIEN,
109 Charles, Bennington, Vt.

Little Things that Helped Make P.A. BIG

By M. N. Beitman

The Radiolek Company

IN the last few years the application of public-address equipment has steadily increased and today the demand for P.A. comes from all fields of activity. In line with the greater usefulness of amplifying equipment new tubes and circuits have done their part in increasing the available power output and quality of reproduction. Applications, circuits, tubes, have all received their due of printed attention, but the small developments that really make modern amplifiers superior to their older brothers have come to life without much notice.

Early amplifiers were built along the lines of the audio sections of radio receiving sets. Commonly a carbon microphone input was used. Occasionally a phono pick-up served as the input source. Then some versatile servicemen incorporated a switch and that was the birth of dual input. Separate volume controls were next offering mixing facilities.

ALONG CAME PADS

Present-day complete mixing and blending facilities are taken as a matter of fact, but there was a real evolution of T pads, L pads, dual potentiometers, and finally electronic mix-

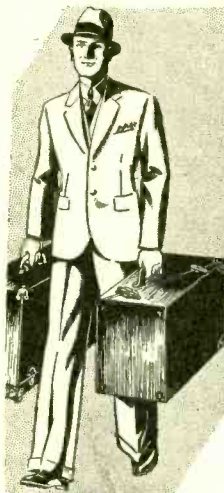

Even a very powerful public-address amplifier may be readily portable. A serviceman is shown carrying a 60-watt system.

ers. Notice the separate microphones and phonograph controls on the best amplifiers today. Either input may be individually controlled and speeches and announcements may be superimposed on a recorded musical background.

For different acoustical requirements, it was found desirable early in the public-address history to cut bass or treble response, as the case may have been. Now every amplifier has a tone control. The usual type simply has a condenser and variable resistor across the plate of the final tube, to ground. The resistor varies the by-pass action of the condenser.

When tubes had directly-heated filaments and gave enough light for book reading, one could tell without an effort if the amplifier was on or off. Not so with indirectly-heated new type tubes and quiet amplifiers. The pilot light came to the rescue. When the amplifier is on, the red bull's eye will let the operator know.

NEATER CONNECTIONS

And what about connections to the amplifier in the old days? Wires hanging, connected here, soldered there, a mess requiring hours of time and a real expert to connect or disconnect. Plug-in connectors eliminated this problem, now anyone can quickly and without a possibility of an error connect all accessories to an amplifier. Notice the handy marked connectors on the unit illustrated.

Sturdy, neat chassis bases became popular offering easy assembly at the factory, protection for all parts in the field, and real professional appearance. All controls are grouped in the front for easy monitoring. The perforated installation shield gives complete protection to the tubes and other exposed parts and permits ample ventilation. For portable applications, special compact carrying cases have been developed. Designed to house the ampli-

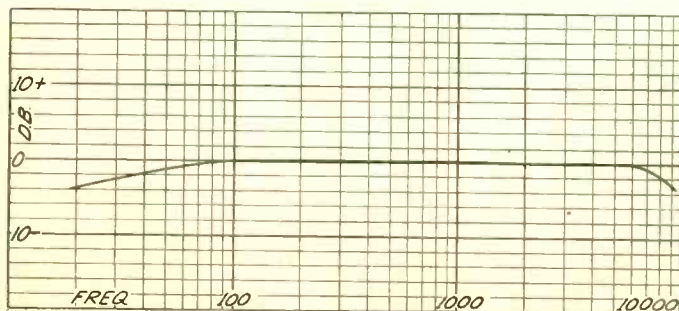

Sample curve of a quality audio amplifier, showing the relatively flat frequency response. Between 100 and 6,000 cycles the curve is shown as absolutely flat. At both extremes there is the usual drop in amplification.

fier and all accessories, the open cases serve as excellent baffles for the speakers. See how easily the man illustrated carries about a 35-watt system.

Real progress is made in steps bringing forth big and small developments. We pointed out some of the small things that helped to make P. A. big.

Besides greatly improved performance of public-address systems there is splendid enhancement of appearance. Balanced layout and attractive housing accompany electrical improvements.

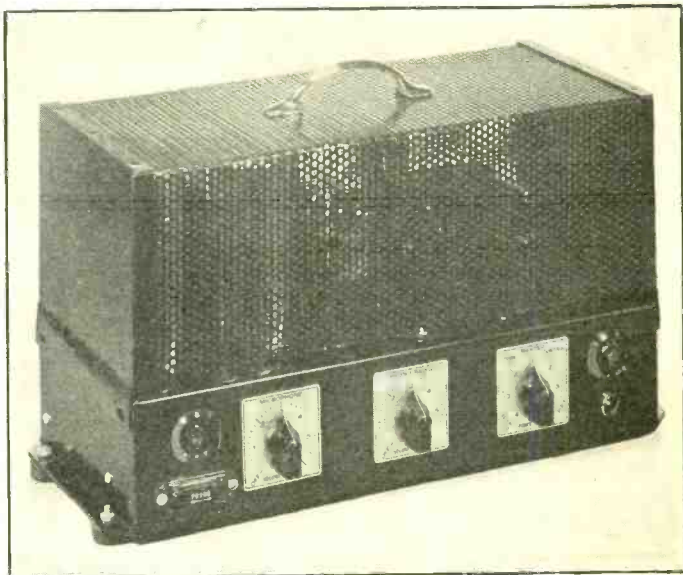

Hotel Antennas Open Profitable Opportunity

The largest all-wave radio receiving system in the world has recently been installed at The Waldorf-Astoria in New York City.

The new equipment covers the band recognized by international agreement for use in world-wide broadcasting. It will pick up the programs broadcast by the giant short-wave stations now located in every important country.

Among the scores of such stations which may be heard at the Waldorf are those in London and Daventry, England; Paris, Berlin, Moscow and Tokio; the Vatican in Rome; Rabat, Morocco; Melbourne, Australia; Caracas, Venezuela; Baranquilla, Colombia; Rio de Janeiro, and Madrid.

One of the objects of perfecting foreign reception in hotels is to enable guests to hear "the home country." Also, of course, guests generally are interested in hearing short-wave stations of other countries.

While the Waldorf-Astoria installation is very elaborate and costly, nevertheless local hotels may improve their short-wave reception, and service men, knowing how to install specialized antenna equipment, profitably solicit such business. Manufacturers of all-wave antenna kits gladly help the serviceman out with handy information applicable to a special job. The general data cover the usual home circumstances, but hotels often require a highly-specialized and more expensive treatment.

Auto Servicing Chain Opens in Metropolis

The demand for and sale of car radios has created another problem, the proper installation and maintenance of these instruments. This work requires special knowledge of both automobiles and radios and also numerous special meters and tools for installing, testing and repairing. The majority of automobile sales and service stations, not being equipped for this work, were forced to turn elsewhere for help on this radio problem. Likewise, the customer, in many cases, found it inconvenient to return a set to his dealer for service.

With universal service stations in mind, the United Auto Radio Service was formed with member stations throughout the metropolitan area (Manhattan, Bronx, Brooklyn, Queens, Westchester and New Jersey). Under its plan, any new auto radio installed by a member station is completely serviced at any other member station, free of any charge, during the 90 day warranty period, thus insuring both the dealer and customer a prompt and convenient service. The list of members is obtainable from United Auto Radio Service, Dept. RW, 231 East 9th St., New York City.

NEW 6A5G HEATER RATING

The 6A5G heater current rating has been increased to 1.25 amperes. It was formerly 1 ampere.

The Voltages Across Tube Elements

How to Determine Potentials and Polarities—By Emil Buchwald

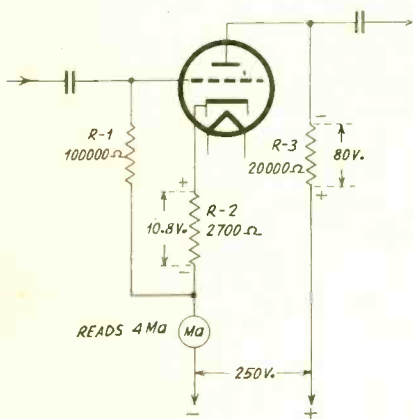

FIG. 1
Type 56 tube as an amplifier.

WHEN the experimenter constructs a radio or an amplifier or any device utilizing a tube, he uses a variety of voltages of different polarities to actuate the device. These voltages are usually measured at the source of supply and if they are equal to the rated voltages that the tube calls for, all is apparently well. This method may be all right as a compromise, but for a high degree of operating efficiency it is important to know the actual voltages across the various elements inside the tube.

The voltages may be measured at the tube socket with a high resistance voltmeter, but this introduces an error due to the load taken by the instrument. The vacuum tube voltmeter is one answer to the solution, but to cover the wide range of voltages used on the average tube requires more than one meter or range. This means a low voltage vacuum tube voltmeter for the low ranges and usually an inverted vacuum tube voltmeter for the high ranges. These instruments are not always available to the average experimenter, so another solution must be found that will give the same results.

FIGURING OUT VOLTAGES

The conventional high resistance voltmeter and a low and medium range milliammeter plus

a little calculation are all that is necessary to determine the voltages within the tube.

Suppose we consider Fig. 1, where a type 56 tube is used as a resistance-coupled amplifier. The grid resistor R_1 is 100,000 ohms, but this value is optional and is merely shown to illustrate the grid-cathode voltage relationship.

R_2 is the bias resistance, 2,700 ohms, and R_3 is the plate load resistance, 20,000 ohms. The applied voltage is 250 volts. A milliammeter is inserted in the negative lead and the current read which is 4 milliamperes. Since R_1 does not carry current when no input voltage source exists at left and consider R_2 , the cathode resistor.

According to Ohm's law

$$E = R \times I$$

Multiplying,

$$2,700 \times .004 = 10.8 \text{ volts}$$

We find that the voltage across the bias resistor is 10.8 volts with the polarity as marked in Fig. 1.

Considering R_3 , the plate load resistance, and using the same formula;

$$20,000 \times .004 = 80 \text{ volts}$$

With these two figures we have the voltage across each resistance.

Since the voltages across the resistors is "lost" insofar as the plate is concerned, we must subtract them from the applied voltage to obtain the plate voltage within the tube.

Adding the two voltage drops,

$$80 + 10.8 = 90.8 \text{ volts}$$

And subtracting from the applied voltage,

$$250 - 90.8 = 159.2 \text{ volts}$$

THE DILEMMA OF POTENTIALS

This is the actual voltage across the cathode and plate as shown in Fig. 1. The grid voltage is equal to the voltage drop across the bias resistor and is shown with the polarity. The voltage across plate and grid is 170 volts.

To the newcomer it may be paradoxical that the cathode is both negative and positive at the same time. These terms, however, are purely relative.

As far as the grid is concerned in the tube, all the other elements are positive and this holds true for generally all circuits where the high vacuum tube is used. Exceptions must

be made, however, for in certain circuits where the grid draws current, the grid is then positive with respect to the cathode or filament. On the other hand, as far as the plate is concerned all other elements are negative. The cathode is positive with respect to the grid and is negative with respect to the plate.

Fig. 1 shows quite clearly that the tube is not functioning at its maximum efficiency as far as voltages are concerned. The plate current of a 56 tube with 250 volts on the plate is 5 milliamperes. The grid bias calls for 13.5 volts. The voltage drop across the bias resistor at 5 milliamperes is 13.5 volts and across the plate load resistor is 100 volts. Adding these two values to the voltage required at the plate we find that to realize 250 volts between plate and cathode the applied voltage must be 363.5 volts!

Suppose we consider Fig. 2, and take a glance inside a type 57 which is being used as a biased detector. R_1 is the bias resistor, 10,000 ohms, R_2 the screen resistor, 750,000 ohms, and R_3 the plate load resistor, 300,000 ohms. The applied voltage is 315 volts and the screen milliammeter reads 0.3, the plate milliammeter reads 0.2 milliamperes.

CURRENTS ADD IN CATHODE LEG

Since the cathode current is the sum of the plate and screen currents we find that, by using the formula as in the first example, the voltage drop across the cathode resistor is 5 volts. The voltage drop across the screen resistor at 0.3 milliamperes equals 225 volts, and the voltage drop across the plate resistor at 0.2 milliamperes is 60 volts.

The voltage between the plate and cathode within the tube is equal to the sum of the plate resistor drop and cathode resistor drop subtracted from the applied voltage.

$$5 + 60 = 65$$

$$315 - 65 = 250 \text{ volts}$$

And this is the effective plate voltage.

The screen-cathode voltage is equal to the sum of the voltage drop of the screen resistor and the voltage drop of the bias resistor subtracted from the applied voltage.

$$5 + 225 = 230$$

$$315 - 230 = 85 \text{ volts}$$

This is the effective screen voltage.

The control grid voltage is equal to the voltage drop across the bias resistance which is 5 volts.

In this example the suppressor is omitted, since it is connected to the cathode and has the same potential with respect to the other elements within the tube as the cathode. It must be remembered that the voltages calculated in the examples hold true only when the tube is in a static condition, that is, no signal voltage applied to the control grid.

EFFECT OF SIGNAL

Obviously when the tube is in an operating condition, the signal causes current fluctuations which are impossible to measure, unless the input voltage is constant. With a constant input voltage, the average voltages within the

tube may be calculated in the same way as when the tube is in a static condition.

When designing a device utilizing a tube, it is a good idea to make a sketch as shown in Fig. 1 or 2, because it shows at a glance the

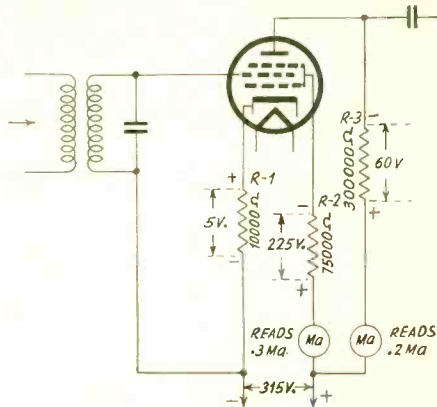

FIG. 2

The 57 tube exemplified.

effective voltages across the various elements within the tube. This will facilitate correct design and help to avoid error, which under ordinary conditions would not immediately become apparent.

Illuminated Clock Given to N. U. Trade

National Union Radio Corporation announced the release to the radio service profession of an electric clock designed especially for the service industry. It is an advertising fixture equipped for brilliant illumination. The face glass size is 16" x 24" bounded by a one-inch two-tone black and silver frame. The face design is a modern effect in five colors and silver mirror. The copy which sells radio service has been developed by a patented process to produce a Neon effect when illuminated. It is said that at night this clock will attract attention a block away.

National Union is giving this clock to radio specialists with the purchase of National Union radio tubes. Samples are being displayed in the showrooms of National Union distributors.



WHY THE "ONE OF"?

I THINK your magazine is one of the best on the market for radio work. Keep up the good work.

Box one, Eldridge, Calif.
RALPH A. SAWIN,

Making Supers Track

By
R. K.
Wheeler

Easy Method Requires Little Apparatus

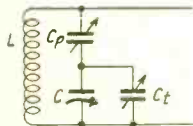

FIG. 1

The basic circuit for the padded oscillator, using the conventional symbols. These are explained in the text.

FROM the vast amount of material published in the past few years on design of superheterodyne oscillator circuits it would seem that this subject is of great interest to the experimenter and practical radio man. While excellent tuning units may be purchased at very reasonable prices, there are many times when it is more desirable or even compulsory to use the material on hand. The job of "tracking" is not especially difficult to the man with a clear idea of what is to be done.

The frequency of the oscillator circuit largely determines the dial setting for a given intermediate frequency. The oscillator frequency is established by the components of the circuit: the coil inductance L , main tuning condenser C , padder C_p , and trimmer C_t , as shown in Fig. 1.

THE COIL IS VERY IMPORTANT

The amount of deviation from the ideal is shown in Fig. 2, where the amount of error in any one part is indicated, and its effect on the tracking. Since C is nearly always part of a gang condenser, it can usually be ignored unless

the plates have been badly bent. Variation in the trimmer C_t is easily corrected, and it will be noted that a 5% error in the padding condenser C_p does not produce a serious frequency deviation. Therefore it appears that the inductance L is most subject to error and favorable to correction.

It is first necessary to find out how much the error in tracking is, and the easiest way is to commit observations to paper, and to that end the writer has devised and used a practical method for a number of years, that requires a minimum of apparatus, usually on hand or easily obtainable. The apparatus required are a signal generator, tuning or output indicator suitable to the receiver being checked, and a variable condenser of approximately the same maximum capacity as used in the receiver. The data to be obtained are two tuning curves on the same paper, one for the r.f., the other for the local oscillator. If the dial is frequency calibrated the amount of error is readily apparent, and if the dial is marked in degrees from 0 to 100 the deviation can be estimated. Fig. 3 shows the suggested layout.

SERIOUS TROUBLE CURED

As a practical example of this method, the following is cited. A number of years ago the author was consulted by a jobber whose receivers after a few weeks service were performing very poorly, losing sensitivity and selectivity. They had been perfunctorily serviced by various service men, with mediocre results, and numerous sets were returned to the jobber for replacement.

It was found in almost every case that the i. f. were lined up at the specified frequency, in

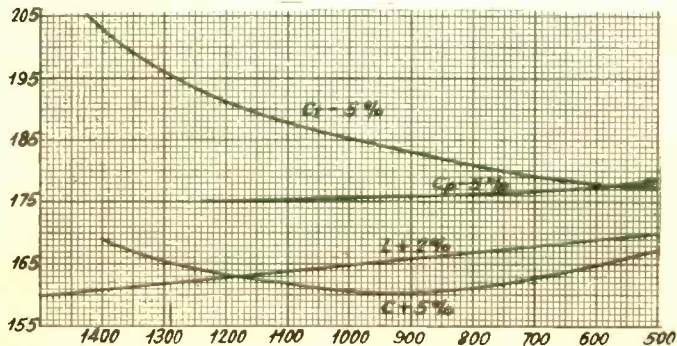

FIG. 2

The graph compares the intermediate frequencies, in vertical column at left, with the station carrier frequencies for main tuning condenser of 5% too much capacity, oscillator secondary inductance 2% too high, padding capacity 5% too small and trimmer 5% too small (read from bottom up). The intended generated i.f. is 175 k.c.

this case 175 kc, and then the main condenser plates badly bent in an effort to effect tracking. A visual inspection disclosed that the coil forms had shrunk sufficiently to allow the turns to loosen, in some cases loosen so badly that complete replacement was necessary. When the tuning curves were run off it was found that the frequency difference between the r. f. and oscillator circuits was far from the 175 kc. In some cases merely shifting the i. f. on the amplifier to the new one indicated, was sufficient solution.

PROCEDURE DETAILED

To obtain the tuning curves the following was done: First the i-f transformers were aligned at their intended frequency (175, 456, etc.), and the end plates of the gang condenser, if badly bent, be restored to their former condition. The oscillator section of the set's gang condenser was disconnected from the circuit, and a separate variable condenser connected in its place. Starting at 600 kc. readings were taken at five points, e.g., 600, 800, 900, 1,000 and 1,400 kc, turning the separate oscillator condenser as required, and adjusting the receiver dial until resonance was shown on the output meter. The set's dial reading, were set down on the chart as precisely as possible, and thus the curve of tuner was established.

The set oscillator circuit was then restored to its original condition, and the detector circuit connected to the separate variable condenser, and the dial settings of the set again noted. However, for clarity in comparison of the graphs, the procedure of obtaining the curve is slightly varied. When the curve is run for the oscillator circuit, the receiver dial is set at exactly the same points indicated by the r-f chart, and the frequency required from the signal generator to produce resonance at that point is noted. Thus, if the work is done with reasonable care the variation in tracking is easily observed.

EFFECT OF TURNS REMOVAL

It will be hardly necessary to run a curve on the r-f tube circuit by this method, unless there is decided evidence that investigation is required. Usually a little judicious checking of the coil with a tuning wand will disclose whether or not such work is necessary.

It should be borne in mind that the r-f tuning is very broad as a rule, and minor variations effect the tracking but little. If the secondary coils of the r-f and detector circuits have the same number of turns, on the same size form, with equal winding lengths, and equal shielding, it may generally be assumed that the matching is satisfactory.

For the home constructors' information, if the same size coil forms and shields are used the reduction of inductance of all coils will be approximately the same, provided the length of the oscillator coil winding is the same as the other coils. This condition may be obtained of course by using large enough wire to fill up the space. In making small changes in inductance, either by removing or adding turns, the change in frequency is closely proportional to the percentage of the number of turns re-

moved, i.e., frequency difference equals:
 $\text{Frequency} \times \text{No. turns removed (for added)}$

Original No. turns

It is believed that the foregoing general method is very practical and economical to apply, especially as it requires only limited

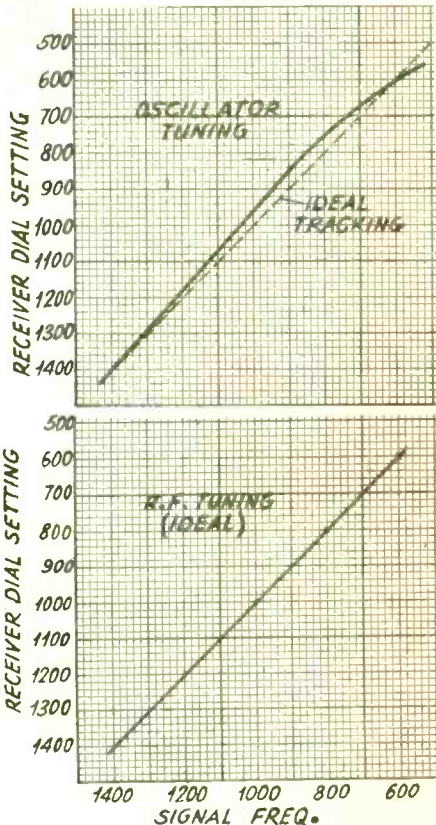

Graphs showing ideal tracking of r-f circuits, with respect to a frequency-calibrated receiver dial. Oscillator tracking is off 50 kc at 900 kc, due to use of too large inductance, with tiedown effected at 1,400 and 600 kc by adjustment of trimmer and padder. In practice it is usually feasible, by using a large enough sheet of paper, to put both curves on the same chart.

equipment and no more than a smattering of superheterodyne theory. For those unable to apply the system, it is recommended that commercial coils and condensers be purchased in matched sets.

There are certain fairly-well established factors in the padding, so that one may follow these in any original winding and padding. The r.f. secondaries are 238 microhenries, the oscillator secondary for 175 kc is 200 microhenries ($C_p = 800-1500$ mmfd.), and for 455 to 465 kc the oscillator secondary is 110 microhenries ($C_p = 350-500$ mmfd.).

tuning, then the tracking is good enough, or, if the note hardly changes in frequency, the tracking is even much better than you could reasonably expect. Notice that the local oscillator inductance need not be changed, the method is rapid, and it is accurate.

stated, this is merely a device, and a dial wrongly calibrated for one purpose is wrongly calibrated for all purposes, and usually means that the condenser is different from the one originally used in running the calibration. In fact, the calibration itself relates the frequencies and

An indicating system for peaking a receiver having automatic volume control is to connect a 0-5 or thereabouts d-c voltmeter across the cathode biasing resistor of an a-v-c tube in the i-f channel. Before a signal is introduced at the r-f or i-f level the meter in this position reads say, 3 volts, and as the signal or carrier is introduced, the meter reads less, until at practically plate-current cutoff it reads zero. Therefore tune for minimum reading, and if zero is reached on any station carrier, too much a.v.c. also is in circuit.

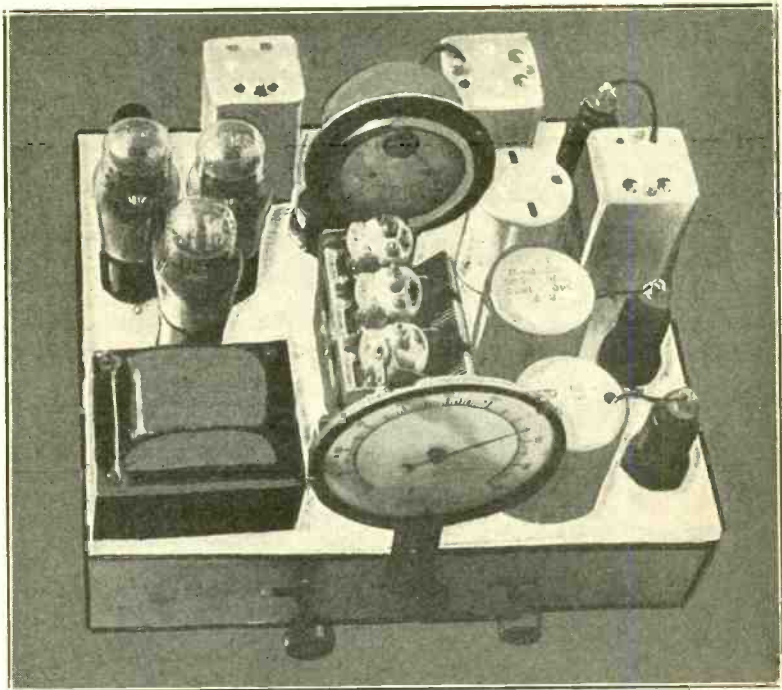

When the proper tracking is established, the dial readings are what they are and can not be changed, without going through the performance as recommended by Mr. Wheeler. This applies particularly to sets with frequency-calibrated dials. The standard broadcast band is considered. The short-wave and intermediate-short-wave bands needs not be given any thought, as the quantity of change of intermediate amplifier frequency is small compared to the station frequencies in those instances.

Nearly all sets have at least some sort of frequency calibration on the dials, and therefore it is important to bear in mind that the frequencies must fall as they are, and more accurate readings are not obtainable by any device. In that respect Mr. Wheeler's method has a bit of an edge, although it must be borne in mind that deviation of the dial calibration from what it should be in the first place is an original error, due to the factory and not to the service man, so any attempt to make it right is merely a makeshift, for it is wrong integrally, and really can not be rectified, only compromised.

The usual compromise is to favor coincidence in the higher frequency region of the standard broadcast band, because of the smaller percentage of the error in the other region, thrown out of alignment from around the middle to about 700 kc, and the percentage error reduced. As

the changes in frequencies to the capacities and changes in capacities, the inductance of the local oscillator, and the frequency of the intermediate channel and of the generated i-f being incidental.

Ohmmeter Method of Measuring Capacities

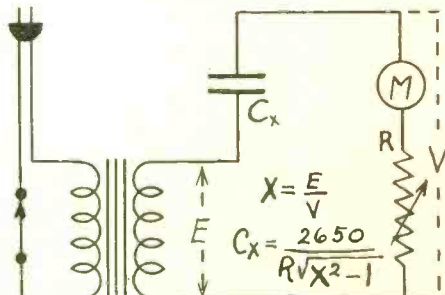

An ohmmeter method applied to measurement of capacity C_x , using the power line a.c. (60 cycles). X is the voltage read with C_x shorted, V the voltage read with C_x inserted. C_x is solved by the formula at lower right.

The Trend of Radio Servicing

By M. M. Brisbin and
W. J. Zaun

RCA Manufacturing Company, Inc.

EACH new radio season brings forth its array of new receivers with circuit improvements and features which are increasingly complex. This necessarily requires that the progression of service standards continue constantly in line with such design evolution. Service development is logically in the direction of

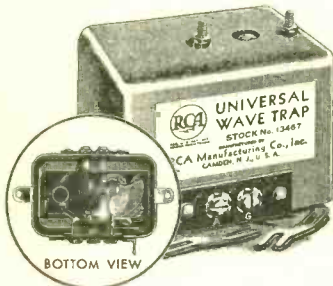

Wave trap manufactured by RCA.

(1) improved serviceability of receivers, (2) simplification of prescribed service methods, (3) standardization of basic parts, (4) improvements in service test apparatus, and (5) increased qualifications of service engineers. These various necessary improvements are being actively promoted by radio manufacturers, not only to insure that their respective customers receive prompt and competent service, but to maintain the stability of the service profession and instill cooperation therewith.

TECHNICAL DATA IMPORTANT

Circuit design is only the beginning of the problem for the manufacturer. The modern receiver must be designed in anticipation of service by careful layout of parts for good accessibility, minimization and simplification of adjustments, segregation of units, and adherence to standardized practices of electrical and mechanical design. These "service specifications" are conscientiously treated by the design engineer, and the chassis construction is accordingly controlled to facilitate repair or adjustment when such is necessary. Sealed assemblies such as were used in earlier designs, which prevent rather than assist servicing, are no longer permissible and not present in modern receivers.

Service methods have developed considerably

in recent years. The abundance of information which is constantly issued by manufacturers, and that which originates in the service field through various publications form the groundwork for this development. Technical data pertinent to individual receiver models, their circuits and service requirements, which were formerly guarded in a jealous manner by the set manufacturer, are now passed along in complete detail to service engineers. General engineering data are likewise frequently distributed for service use. Superficial information of sales or advertising nature is avoided in these publications in recognition of the serviceman's need for, and interest in details of an engineering nature which enable accurate interpretation of new circuits and the principles which underlie their operation. The trend of style for published technical service information is directing itself to better organization of data, tabulation of procedures—such as alignment operations—and increased emphasis on diagrammatic information.

Printed information is, however, not considered sufficient. Service lectures are frequently conducted for service men by technical representatives of radio companies to augment printed dissemination of knowledge of a particular as well as a general nature. In these lectures fundamental principles controlling the design of instruments are discussed and demonstrated. Cooperation between servicemen and design engineers is thus encouraged with the result that the viewpoints of both are exchanged with mutual benefit. The RCA Manufacturing Company has been very active in sponsoring an educational program of this sort which is especially designed to meet the needs of servicemen.

REPLACEMENT PARTS

Promptness of receiver repair is extremely important to the customer and is governed by the availability of replacement parts. Manufacturers maintain supplies of genuine service parts which are similar in design to those originally used in factory assembly. Improvement and standardization of their designs are carried out as experience increases so that the use of standard factory parts always affords the serviceman protection against obsolescence. Development of accessory parts which extend service activities to improvements in old receivers, and provide solution to long prevailing problems, is now taking place. As an example, the RCA Universal Wave Trap may be readily adapted to almost any type of receiver to reduce the harmful effects of blanketing, interference from strong local stations nearby, unfavorable beat combinations of local signals, direct i-f pickup and cross modulation. The normal tuning range of the trap extends from 430-1,700 kc, and with minor rearrangement of connections can be tuned to frequencies as high as 6,000 kc. Mounting provisions are simple and permit ready adaptation to many types of receivers. The magnetite-core, Litz-wound inductance is parallel-tuned with an air dielectric capacitor forming a high Q circuit which produces an average attenuation of 30 db. Other accessory parts, which adapt as readily for different purposes,

include extension loudspeakers, tuning tube kits, noise-reducing antenna systems and phonograph adapters.

Test apparatus for service work has developed with great rapidity. Many new instruments having wide application are now within the reach of the average serviceman. Oscillographic alignment apparatus is becoming an outstanding modern service requirement. The RCA Model 150 Electronic Sweep Oscillator and the Model 151 Cathode-Ray Oscillograph represent the latest advance in test equipment of this type. These instruments not only fulfill

servicing of radio receivers, but they will give the operator an intimate knowledge of the basic principles of operation which will be invaluable in years to come.

It is no secret that we are on the eve of a revolution in broadcasting and receiving technique. It will not be long before receiving sets are in use which will bear little or no resemblance to present-day models. To the man who is well grounded in his fundamental theories these sets will be within his capabilities. To those who are not, the road will be hard and lead toward elimination. Consequently it be-

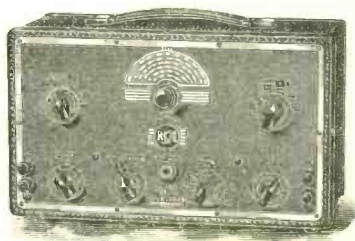
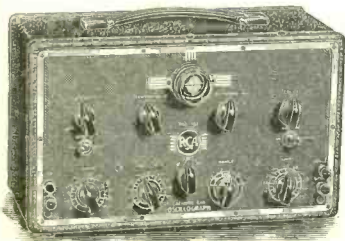

RCA has a new oscillograph, using the 913 tube (left), with amplifiers, sweep tube and rectifier, also a new r-f test oscillator with electronic sweep (right), dispensing with a separate frequency modulator.

the servicing requirements of present receivers, but their designs foresee use with future receivers. They are shown above.

QUALIFICATIONS MUST PROGRESS

The oscillator, besides having a wide frequency range, incorporates an electronic sweep circuit which is controllable over a range from zero to 40 cycles. Provision is made for either unmodulated output or 400 cycle amplitude modulation. A jack permits introduction of external modulating signal, which is often convenient for checking over-all response of a receiver. The oscillator may also be modulated with music for listening tests. The oscillograph has a one-inch screen. Controls and terminals are included to provide the maximum flexibility of application. The combined arrangement of oscillator and oscillograph is especially adaptable to portable applications.

Qualifications of the service engineer must of course progress with the industry. Knowledge must not only encompass the circuits and characteristics of present receivers, but should extend to the older types which remain in use, and, as well, be of such basic nature that future developments may be understood.

Analytical ability which enables prompt recognition of causes from their effects is likewise an important constituent distinguishing a qualified service engineer. This type of ability will develop from systematized training, patience and interest in seeking conclusive facts, and avoidance of superficially indefinite diagnosis or workmanship. The use and studied application of modern testing equipment, such as the cathode-ray oscillograph, and the electronic sweep oscillator, will not only expedite

hooves every service engineer to work with at least one eye toward the future, and no better way can be suggested for doing this than by owning modern testing apparatus which will allow him to study the electrical fundamentals which never change.

Oscilloscopes in Greater Use, Says Ghirardi

From recent letters received from servicemen all over the country, Alfred A. Ghirardi, well-known writer and authority on radio subjects, concludes that the use of the cathode-ray oscilloscope in radio service work is increasing very rapidly. This trend he attributes to the recent introduction on the market of oscilloscopes selling for \$45 to \$50 with the new small cathode-ray tubes. These lower-priced outfits have brought the cathode-ray oscilloscope within the financial reach of more servicemen.

Mr. Ghirardi states that servicemen are using oscilloscopes mostly for aligning r-f and i-f stages of superheterodyne receivers. Other common uses are found in measuring capacity and inductance, testing overall receiver sensitivity, testing overall audio fidelity, localizing audio distortion, testing overall audio fidelity and localizing distortion in a-f amplifiers, and for checking receivers for intermittent reception.

Mr. Ghirardi's publishers, Radio & Technical Publishing Company, 45 Astor Place, Dept. RW, point out that all these subjects are discussed in full detail by him in the cathode-ray oscilloscope section of his book, "Modern Radio Servicing."

Servicing Job or Profession?

By Leland S. Hicks

Thordarson Electric Mfg. Co.

NO one today will deny the fact that Radio Servicing can well be termed "Established Business." A quick glance at several very en-

years to come. Ten million sets is the sales quota for 1937. Assuredly there is a future in Service, a profitable, growing future.

Job or profession, the individual serviceman's future depends on three things. Each is essential, and the possession of all three will assure him success in an interesting, well paid field—a professional success!

KNOWLEDGE FIRST REQUISITE

The first requirement of the modern serviceman is that he have thorough knowledge of his field.

This can be gained in several ways. Experience is a good school, but it teaches slowly, and often not completely. Therefore, experience should come after theoretical knowledge has been gained. It is essential that service-

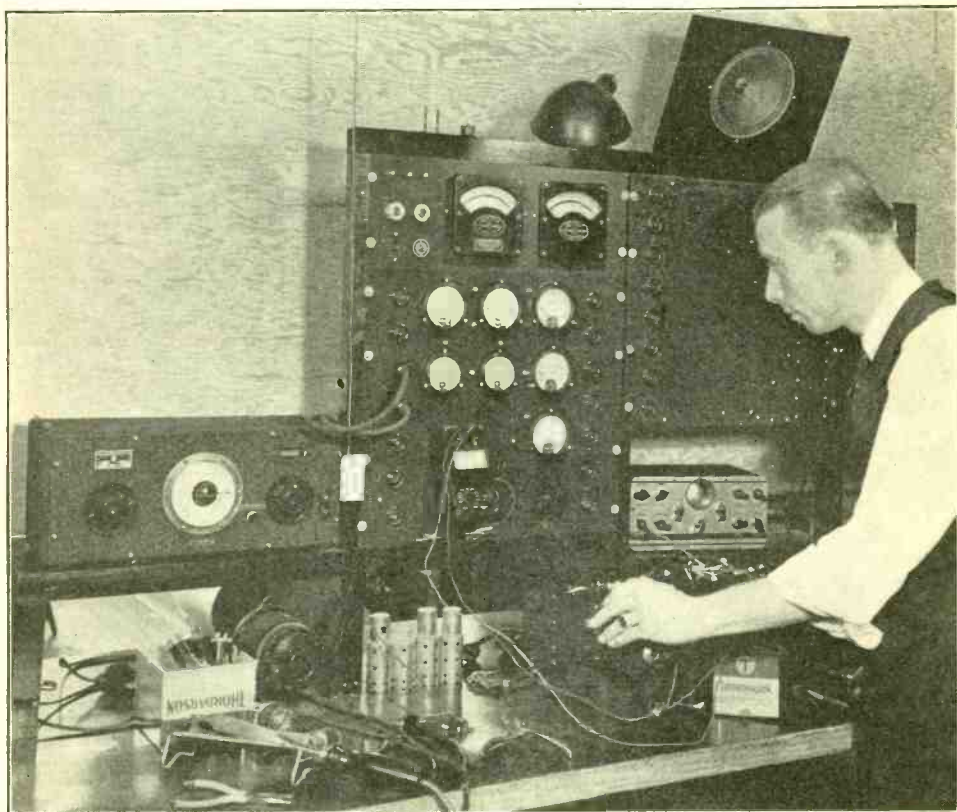

Acoustical measurements being made in the Thordarson laboratory. Just above the engineer's hand is shown the cathode-ray oscilloscope that Thordarson produces, also obtainable in kit form.

lightening facts will prove this contention beyond any doubt. Servicemen earned \$75,000,000 for labor alone in 1936, bought \$45,000,000 worth of replacement parts and sold over \$31,000,000 worth of replacement tubes. Then, to insure its future, dealers and servicemen sold 8,000,000 new sets to increase the 28,000,000 already in use. Considering trade-ins and obsolescence, there should be over 35,000,000 radios for the service profession to work on in the

men study, in order to gain a modern and thorough knowledge, which includes mathematics, electrical theory—especially alternating current theory—salesmanship, business fundamentals, and accounting.

A future is impossible without a profit, and profits are impossible without sales ability. The development of a pleasing, yet strongly convincing, approach to customers is a necessary asset, and every opportunity to cultivate it

should be carefully attended. But, the sale is not the end of the worry. The service charge must be based on sound cost information, if the serviceman is to realize a fair profit. Again, the smallest service shop is not immune from filling out tax returns, so a complete, though simple, accounting system is a necessity.

This varied knowledge is found in the well-trained man. Attending a good radio school, or completing a recognized correspondence course, aids immeasurably; but, in addition to such training, a program of continual home study must be carried out, to keep abreast of such developments as volume expansion, a. f. c. and cathode-ray oscilloscopes.

APPLICATION OF KNOWLEDGE

Old Man Experience is the patron saint of the second requirement to a professional future, the application of knowledge.

Jack Brown, as a boy, was a ham. He enjoyed working with radio and decided to make it his profession. He only attended high school, but made good marks in math, mechanical drawing, and the short course in radio, taught by the physics instructor. He saved enough money to attend one of the better radio schools, where he learned more theory and gained the experience of working on receivers. This training helped him get a job with a local service shop, giving him more valuable experience. He finally started his own business and is now well on the way to success in the field he enjoys, and for which he is fitted.

Experience is a necessity, for, after all, a rapid, accurate diagnosis is not possible with training alone. The young man, who opens a business without this experience, is handicapped. Cutting prices with the intent of drawing business from the experienced man, will not help, either, for customers will spread word of his inefficiency and his reputation will be permanently ruined. A good way to get started on the right path is to work for a reputable shop under capable supervision, then open your own shop, full of confidence created by experience and proven ability.

What of equipment? It is the third requirement, and equally important with the other two. Each new circuit, each new tube brings up new service problems and requires new equipment. At one time the average serviceman seldom used an r-f oscillator. He peaked the trimmers of the old t-r-f sets at 1400 kc by tuning in a local station, and he used his ear as an output meter.

Today, an r-f oscillator is not only a necessity, but it must be modulated at will with a sine-wave audio signal; it must be "wobulated" over a narrow band of frequencies, and it must cover from 150 to 20,000 kc. The human ear has even been debunked and accused of giving logarithmic indications instead of linear reproduction. The output meter, too, must be discarded if a modern high-fidelity, variable-selectivity superhetrodyne is to be aligned.

The future method of servicing will be built around the oscilloscope. A visual picture of what is happening in a receiver will give more information than any other method of servicing,

to the man with the training and experience necessary to understand what he sees.

This new tool will do many things alone, but, in conjunction with a few other pieces of equipment, it will do infinitely more. The most important aid to the "scope" is the frequency-modulated oscillator, which sweeps a band of frequencies across the desired frequency at a definite rate of speed. With this combination it is possible to align the i-f and r-f sections of high-fidelity receivers and adjust automatic frequency control circuits.

Intermittants, the bugbear of the service profession, can be easily located by feeding in a signal and viewing the output, stage by stage, with the oscilloscope. Distortion in the audio section can be tracked down and the defective part located by using the "scope" and an audio oscillator. Auto vibrators can be tested, either in the car or on the bench, with the oscilloscope alone. All of these tests and measurements can not only be made accurately by the use of this new method, but also can be made in a fraction of the time required by any other method.

Anyone entering the service profession should consider the future in buying his test equipment. New and more intricate circuits are certain to be introduced, requiring equally new test equipment. If the test equipment bought is out of date now, just think how completely out of date it will be two or three years from now. Buy up-to-date instruments, and, preferably, buy associated groups of instruments, especially in cathode-ray equipment. In other words, be sure the r-f oscillator is capable of frequency modulation, or get a wobulator for the present oscillator. Obtain an audio oscillator with a sine-wave output for easy comparison on the oscilloscope.

TELEVISION

The experienced serviceman need not buy all his equipment. Home-made oscillators, both r-f and a-f, can be as efficient as factory-built models, if the constructor has the knowledge and experience necessary to do a complete job. The Thordarson oscilloscope kit is an example of professional type equipment that can be built to render great efficient service at a saving in cost.

With television so much "in the public eye," another field is opening for the well-trained, well-equipped serviceman. Apparently the cathode-ray method will be used when this new art is released to an eager public. The demand for men experienced with cathode-ray equipment is going to exceed the supply, and the well-trained, experienced, well-equipped serviceman is going to be far ahead of his less fortunate competitor. With high audio fidelity producing as many problems as it does, it is easy to realize the number of problems that will crop up with the fidelity necessary for clear pictures.

All in all, the future is bright for the serviceman. Be he specialized in home receivers, auto receivers or eventually in television, he may write his own social security plan. But he *must* be technically trained, he *must* be experienced, and he *must* have modern equipment.

Business and Sales Next By Tobe Deutschmann

WITH the development of more delicately balanced radio circuits requiring a high degree of engineering skill and a variety of precision equipment for satisfactorily adjusting them, the radio serviceman is rapidly raising himself out of the class of amateur tinkerer and is becoming truly a service engineer. Every serviceman who hopes to remain in business now finds it necessary to own and thoroughly understand the use of instruments which until recently were found only in the most completely equipped laboratories. Fortunately such instruments have been made available in a price range that renders them accessible to any active serviceman.

NEXT BIG STEP

In my opinion the next important change in the radio service industry will involve sales and business technique rather than engineering. The serviceman who contents himself with merely repairing radio receivers is not only failing to render a complete service but is missing many opportunities for profit.

It is probably true that at least 75 per cent of all radio listeners are troubled with man-made static and because of this fact are unable to obtain the uniformly satisfactory radio reception they expected when the receiver was first purchased.

The alert serviceman will attempt to ascertain whenever a service call is received whether extraneous noises hamper radio reception and, if so, what may cause these noises. In a sur-



Tobe Deutschmann Held Fast Through the Years

Tobe Deutschmann is one of the few pioneers still identified with his original company, formed when radio "began."



TOBE DEUTSCHMANN

His early condenser in the silver-covered container, known to all old-timers, is still a product of today. His coined-words, "B" Block and "A" Block, have been part of every A and B eliminator.

Tobe Deutschmann has never tried the easy things. His early work and labors in the field of radio noise elimination have placed his present organization

as outstanding leaders and recognized authorities.

The efforts of Tobe Deutschmann were at a time when few realized the import and necessity for radio noise elimination. Many of the practices recommended by him are now in use throughout the industry.

prisingly large number of cases it will be found that the interference originates in the home of the set-owner. When this is found to be the case, the adjustment of defective equipment or the installation of suitable interference eliminating Filterettes will better satisfy the customer and will at the same time provide additional profit from the same service call.

The elimination of radio interference is of vital importance to every radio serviceman because it will allow listeners to use their receivers for longer periods of time with the result that new tubes and receiver adjustments will be required earlier than would otherwise be the case.

TELEVISION'S WARNING

With the approach of television, interference elimination assumes increasing importance because the blotting out of visual images is bound to be much more offensive than is the interspersing of extraneous noise with music or speech. It, therefore, behooves every serviceman to familiarize himself with the methods and materials that have been proved most effective in suppressing radio interference at its source.

The Engineering Department of the Tobe Deutschmann Corporation, Filterette Division, will gladly make available to all servicemen the information gathered during the past fifteen years of pioneering experience which has gained for this organization recognition as the authority on all matters pertaining to the elimination of man-made static. Address Dept. RW, Tobe Deutschmann, Canton, Mass.

What is Vital for Servicing

By Joseph T. Bernsley

Chief Engineer, Superior Instruments
Company

QUITE a few persons who have been doing service work on and off, and have decided to confine all their activities to it, or who are just entering the service field, write in asking what equipment we believe they should buy. Usually there is some notation to the effect that the instruments can be purchased only one at a time, because of insufficient funds. We promptly answer the letters in detail. Many of them include individual queries, so a form letter would not suffice. It is very encouraging to note, from an examination of our records, that those service men who realize instrumentation must be regarded as seriously as their success, soon are able to possess a complete complement of required equipment. We do not yet manufacture all this equipment, by the way.

On the other hand, some servicemen will no doubt remark, as they do in correspondence, that there seems to be no end of the equipment one must have, that every so often some new kind of device is introduced, and therefore the serviceman is working for the instrument maker, who gets much of his money, and if only there would be an end to the steady stream of new servicing equipment there would be some solace in life and some profit left for the serviceman.

We can not at this time undertake a discussion of the economic factors of the servicing industry, but can remark reliably that those servicemen who are best equipped by training, experience and instruments are best able to prosper, while those who try to string along on meagre or inadequate equipment find the going getting tougher and tougher.

MUST KEEP ABREAST OF SETS

It should be borne in mind that precision instrument makers such as we are do not have much, if anything, to say about what equipment is needed for service work. New receivers are brought out each year, with more and more complicated refinements, and our own engineering staff has to keep constantly alert to be fully abreast of all these developments. The servicing instruments that are designed therefore are based on requirements that the receiver makers indirectly specify. If automatic volume control is introduced in receivers one year, automatic frequency control another year, and automatic selectivity control still another year, it is the serviceman's responsibility to be able to cope with the repairs required for such receivers, as well as for old sets. The instrument makers are simply taking a burden from his shoulders,

solving part of the problem for him, and only requiring that he pay a fair price for the instrument, just as he himself requires that his own customers pay a fair price for the work he performs.

It may be surmised therefore that the instrument makers wish, also, that they might ride along for a few years on the instruments they have, instead of engaging in the very costly experimental and design work, not to mention extensive field tests required before a new instrument may be safely placed on the market.

BOTH IN SAME BOAT

So the serviceman should feel that the instrument maker is in the same boat with him, also pulling hard on the oars, and hoping, too, that the sea will remain calm indefinitely, which, of course, it will not, for something new will arise

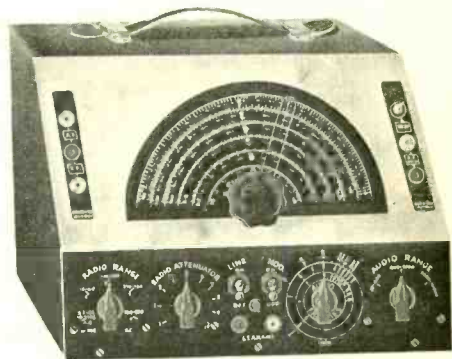

The Superior Genemeter, with calibrated r.f. and a.f.

surely, to create a disturbance, and problems must be met almost as fast as they arise, if we are to remain in business and prosper, servicemen and instrument makers alike.

There is no implied criticism of the set manufacturers, because they, too, must introduce such improvements as are important to the sale of receivers, for should receiver sales decline, servicing business will surely decline, while as it is more sets have been sold in the past year than ever before, which means more work is ahead for the serviceman, much of it requiring modern equipment.

The need for a complement of instruments to cope with all the requirements, new or old, naturally requires that a considerable investment be made before one can be properly equipped in the service field. The first requirement for successful servicing is a good theoretical background, obtained through a correspondence course of one of the better-grade schools, or by taking a course at a personal attendance school.

SCHOOLS RECOMMENDED

Two of the best correspondence courses are offered by National Radio Institute, Dept. 7EM4, Washington, D. C. and Sprayberry Academy, Academy of Radio, Dept. RW, 2548 University

(Continued on following page)

(Continued from preceding page)

Place, N. W., Washington, D. C., while a very thorough personal attendance course in radio generally is given by RCA Institute, Department RW, 75 Varick Street, New York, N. Y. Radio courses also are offered at schools that teach other scientific subjects, such as Massachusetts Institute of Technology.

Once in possession of a good theoretical background, the intended serviceman has to get some experience, and this he may do either by working for some one else, or by going in business for himself. It is rather tough on the customers to start in trying to fix radio sets without some field experience, for a great wealth of knowledge is acquired in the field, and it is of a more extensive and varied type even than that acquired by the experimental work done in connection with correspondence courses or shop work in attendance schools. The field experience is absolutely requisite, and one may prefer at first to work for some servicing organization, but whatever one decides to do, he must possess instruments.

INSTRUMENTS NEEDED BY EMPLOYEES

Even the service organization looks to the men it employs for field work to possess certain



The Allmeter, 21 instruments in one.

instruments of their own, though more costly instruments may be on the organization's service bench, for use on sets that necessarily must be brought in. More and more servicing is being done in the laboratory, less and less in the customer's home, which is no place to fix anything except to install a new tube or tighten a set-screw or repair or install an aerial.

Since in either case, working for one's self or for some one else, instruments are needed, the question naturally arises, What is the most important instrument, the one I must get first? The answer is, A signal generator. That is absolutely necessary, it is something for the absence of which one can not safely compromise, and failure to possess one puts one at such a serious disadvantage that any one feeling he can't afford a signal generator should acknowledge that he can not yet afford to tackle the service business.

INSTRUMENTS DESCRIBED

It has been intimated that the number of instruments finally to be possessed will be

rather costly, but that depends a great deal on one's basis of comparison. Some years ago we entered the service instrument manufacturing field with the intention of finding economical ways of producing highly accurate results, and we spent many months developing and designing equipment that was stripped down to its utter essentials, and yet which rendered the full required service. Therefore we were able, as we believe, to establish the world sales record for the first instrument we made, a signal generator. So large did the production finally become that gradually we were able to reduce the price from the original \$16 to \$10.40, the lowest price in the field for an all-wave signal generator, 100 kc to 22 mc, all on fundamentals, direct-frequency-reading, with modulation on on-off service, all switch-operated from the front panel, and affording also condenser and other leakage tests, up to 100 megohms. This instrument has become famous as the Oscimeter and is in use in many thousands of service shops daily.

Some will require an instrument of somewhat greater flexibility, and therefore we also have an all-wave signal generator, 100 kc to 22 mc on fundamentals, and to 105 mc on harmonics, without confusion, all frequencies direct reading. However, in addition to the leakage test and the modulation on-off service, we have included variable and calibrated audio frequencies, direct-reading of course, in three bands, 24-400 cycles, 400-5,000 cycles and 5,000-10,000 cycles. Thus audio amplifiers can be checked for fidelity and other tests made, with closely-known, bandsread-selected frequencies, where choice of the frequency is important. In both models the audio frequency or frequencies may be taken out independently of the radio frequencies, i.e., the audio tube is not confined to modulation, but yields independent audio, the same as an independent audio oscillator would.

VOLT-OHM-AMMETER SECOND

Second in importance, we believe, is the instrument for making an assortment of current, voltage and resistance readings. While there are many splendid ones on the market, it was not our intention to offer simply instruments somebody else makes, and sell them at a lower price, but we endeavored first to produce the maximum of service, and still keep the price reasonable. Therefore we have an instrument, called the Allmeter, that reads a-c and d-c volts, a-c and d-c currents, capacity, decibels, henries and resistance. It should be noted that a-c currents are included, an unusual feature, and on certain occasions very important to determine. The a-c feature gets away from the limitation from which a d-c measuring device suffers, and permits measurement of reactive components. For instance, capacities from .01.10 mfd. can be clearly, accurately read, and higher capacities to 50 mfd. not quite so clearly, but sufficient for the purpose, since even 10 per cent. variation in high capacity measurements, 10-50 mfd., is immaterial.

The inductance range is 5-1,000 henries, with accuracy of 2 per cent. from 10 to 1,000 hen-

ries, accuracy undetermined from 5-10 henries, because then the unknown d-c resistance of the coil has a very large effect, and a computation would be necessary for 2 per cent. accuracy. However, all choke coils, etc., for audio frequencies may be measured when loaded or unloaded, i.e., independent d.c. may be run through the coil, hence measurement made of a speaker field or a B supply choke right in an operating receiver or transmitter.

HOW DECIBELS ARE SCALED

The decibels are plotted for two ranges, minus 12 to plus 10, the second scale adding 20 db to the first. The voltage ratio formula was used for the calibration, since the device calibrated was the a-c voltmeter on the 0-15-volt range, the plus 20 db being for the 150-volt range. So the practical range is minus 12 to plus 30 db, with overlap, a total spread of 42 db. However, by using a higher zero level than the one on the meter (4.75 volts), the negative region may be extended, as addition and subtraction apply directly. If the high scale is used at maximum (level 150 volts), then the readable attenuation is to minus 42 decibels.

Instead of just one resistance scale there are two scales, a special one for low ohms, less than one ohm to 500 ohms, the other scale, 500 ohms to 500,000 ohms. On the low ohms scale condensers and other devices may be tested for shorts. The Allmeter is also a 0-15, 0-150, 0-750-volt vacuum tube voltmeter to 10 mc, drawing a little current.

UNSELFISH RECOMMENDATION

This measuring instrument, the Allmeter, is sold also at \$10.40, complete with rectifier and test leads. The direct-reading Superior meter is a 0-1 milliammeter (1,000 ohms per volt), having the d'Arsonval movement, and is fan-shaped, 4.5 inches overall. Switch operation applies throughout, and all services are from a single pair of binding posts.

The third instrument is a tube tester, and we make one that follows the approved emission test circuit, and which also sells at \$10.40.

Our fourth classification is the cathode-ray oscilloscope, which we make in two models, one for \$24.60, using the 913 tube, one-inch diameter, and equipped with amplifiers, and the other using the 3-inch diameter tube, also equipped with amplifiers, and selling at \$49.50.

A WORD OF ADVICE

Our present production line is devoted to the above instruments, but we do not maintain that we manufacture all the devices a serviceman should have. We believe that it is absolutely essential for him to possess a wobbler, so that band-pass characteristics of amplifiers may be viewed, for instance, high-fidelity sets flat-topped, which can not be done readily by any other method than by use of the cathode-ray oscilloscope and wobbler. We are arranging to include a wobbler in our pro-

Bernsley Grew Up With Servicing Business

The radio history of Joseph T. Bernsley presents a most diversified background as well as a most interesting account. Many of our

readers will recognize him as a prominent writer of technical radio subjects, yet this is really only one of his accomplishments. He has served with the engineering divisions of several major radio manufacturers, notably RCA-Photophone, Kolster, and the old DeForest Radio Company, in addition to having



JOSEPH T. BERNSLEY

been the managing editor of "Radiocraft" magazine and associate technical editor of "Radio News."

During the depression years he took to radio servicing, and thereby gained a considerable knowledge of the idiosyncrasies of that profession, as well as a full realization of its economic factors. Consequently, the recent years found Bernsley associated in manufacturing servicing test instruments which were "simple-to-operate, precise but economical"—since he learned, through his previous experience, that these were the fundamental requirements of all servicemen.

He is actively engaged as chief engineer of Superior Instruments Company, in charge of all design work and production checking, and in developing a full line of servicing instruments which will not only meet the aforementioned requirements, but will be priced at low levels. This, he believes, will constitute a major improvement in the servicing industry.

His age is only 32; his radio experience began more than 15 years ago, and one of his ambitions is to improve the conditions in the servicing field.

duction late this Summer, and also a vacuum-tube voltmeter of the infinite impedance type, which we also regard as essential equipment for a service man.

With such instruments as we have outlined he will be able to cope with the servicing requirements, and if anything that is absolutely vital for servicing is to be introduced, it will have to be something additional to what has been outlined. Extra equipment of course is handy, sometimes very useful, to perform special measurements, and some makers combine instruments we list as separate units, but for the run of service work, and a good job at that, we have listed the prime essentials, and assumed the possession of an analyzer plug to "free-point" the receiver circuits.

What a Little Resou An Electronic Voltmeter

Built Around the 6E5

Geared Dial,
Easy Optical
System

By E. L. Deeter



FIG. 1

The instrument panel as built by the author.

WE need only to apply proper operating voltages to the plate and target of the 6E5, devise a calibrated scale for checking the shadow angle and we have a simple, efficient and dependable vacuum-tube voltmeter, electronic in its entirety. As a cathode-ray voltmeter this tube is sensitive to very small voltage changes, a condition not enjoyed by larger conventional cathode-ray tubes such as the 913, unless amplification is used. This is because the 6E5 is also an amplifier within

itself, and for this reason requires only a very simple layout for operation.

Having built several voltmeters around the ray indicator tube, the author herewith passes on to the reader some information regarding the building and use of such equipment. A few words in review might not be amiss.

OBTAINING ACCURACY

A simple method of constructing a dial plate and calibrated scale is shown in Fig. 5. The electrical circuit, Fig. 3C, includes a variable resistor in the cathode line, producing a voltage drop of small value to facilitate the zero reset of the shadow angle in relation to the scale.

Accuracy in calibrating is best obtained by the use of a number of new flashlight cells, each to represent a value of 1.5 volts, 1.54 actual. A three-section voltage divider placed progressively across each cell will allow graduations of one-half volt steps over the entire scale. Such a divider should consist of a total of at least 60 ohms, 20 ohms in each section. A mark half way between such designations on the scale will represent quarter volt points.

A variable resistor across a storage battery, with a reliable voltmeter in the circuit, will allow still smaller designations on the scale, but due to the limited angle change the marks would soon convene as they became more numerous. The alternating current scale may be calibrated with the hookup shown in Fig. 3B, obtaining the various voltages by the use of a variable resistor in parallel with the filament winding of a power transformer.

DIFFICULTIES OVERCOME

In operating a simple voltmeter such as the one just described, we recognize at once two major disadvantages. If accuracy to a high degree is desired, it should be possible to determine definitely the aligning of the shadow angle with the scale. This becomes a problem due to the distance intervening between the scale and the target disc. This fault is further

urcefulness Will Do

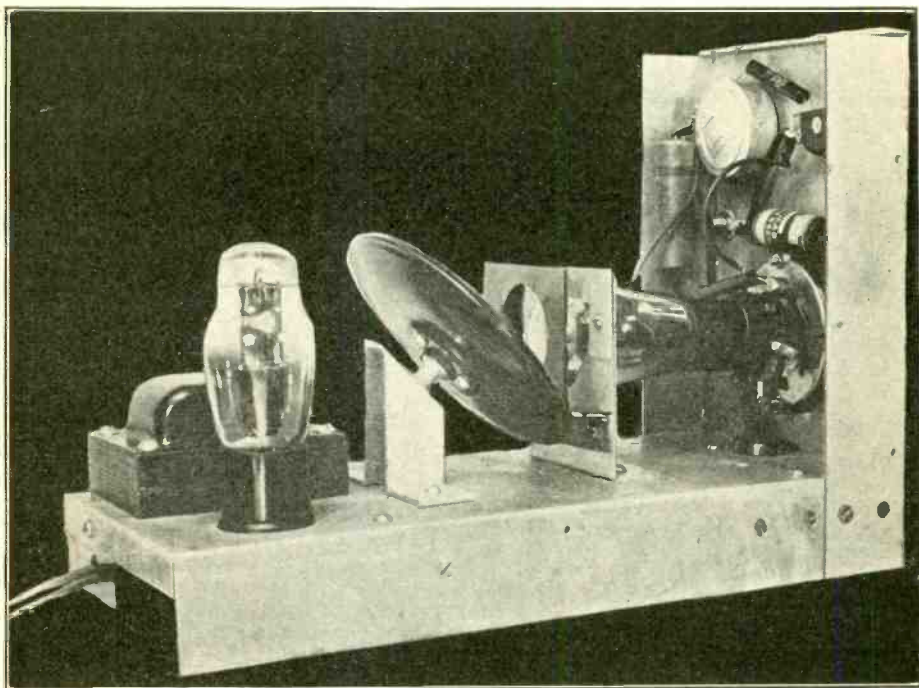

FIG. 2

This side view gives an idea of the optical system. The square metal frame with the circular opening immediately out from the mirror supports the aligning pointer, a small brass hook at the base of the circle. At the base of the tube socket is the reducing gear. Flexible wires to the socket terminals wrap once around the driving axle between the gear and the socket, before passing out the base of the chassis.

magnified because of the small angle change and crowded dial.

A voltmeter in which these difficulties have been overcome is shown in the photographs, Figs. 1, 2 and 7. Both in the optical and mechanical properties were made use of in solving the problem. Rotating on an axis along its length, the tube is actuated by a five-to-one reducing gear, so that the hairline dial pointer covers an arc of 180 degrees, with seven linear inches of dial graduations on the outer scale.

The illuminated target disc is viewed through a small aperture in the top of the cabinet, the image being reflected by use of a mirror set at right angles to both the tube's apex and the viewing aperture.

Interposed in the line of sight is the aligning pointer. This pointer, designated in Fig. 4, is placed directly out from the glass envelope's dome. In making measurements the tube is rotated until the radius of the illuminated edge

becomes tangent to the aligning pointer, as seen from the viewing aperture.

The viewing aperture, a small Bakelite bushing with an inside diameter of one-quarter inch, is located six inches distant from the reflecting mirror. Because the aligning pointer is also some small distance from the target disc, it becomes important as to the location of the viewing position above the aperture, a slight deviation from the correct position resulting in erroneous readings.

RELIABLE, INEXPENSIVE SYSTEM

The correct position is obtained by use of a small wire stretched across the opening of the aperture and parallel with the illuminated edge to be aligned. This wire presents a semi-opaque line across the view and allows one correctly to place the head above the instrument when taking measurements. Operating without ex-

(Continued on following page)

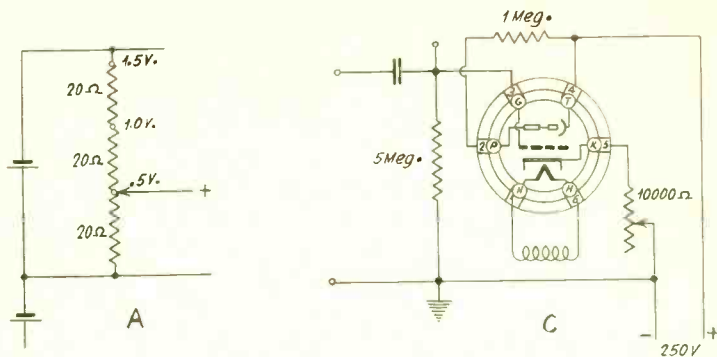
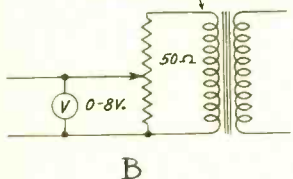

FIG. 3

The use of a voltage divider across each cell progressively allows obtaining small value dial designations, with proper values designated in A. The filament winding of a power transformer is used for the AC scale, shown in B.

FILAMENT WINDING OF POWER TRANSFORMER



B

(Continued from preceding page) pensive lenses, this optical system proves its reliability because any number of impartial operators will arrive at the same readings. The view presented by the aperture opening is illustrated in Fig. 6.

The instrument panel, shown in Fig. 5, includes a calibrated scale for resistance measurements, running from .5 meg. to 50 meg. Resistor and condenser sizes are designated in the wiring diagram of Fig. 4. A bypass condenser from the tube's plate to ground affects

the linearity of the alternating current scale, therefore becoming an important factor in the calibration. With the model shown, designed for audio frequencies, this bypass was only .005 mfd. A larger condenser here would crowd the scale on the higher readings.

A negative voltage of sufficient intensity to close the shadow-angle of the tube is made available by throwing a toggle switch on the panel. This voltage, obtained by the use of a

(Continued on page 38)

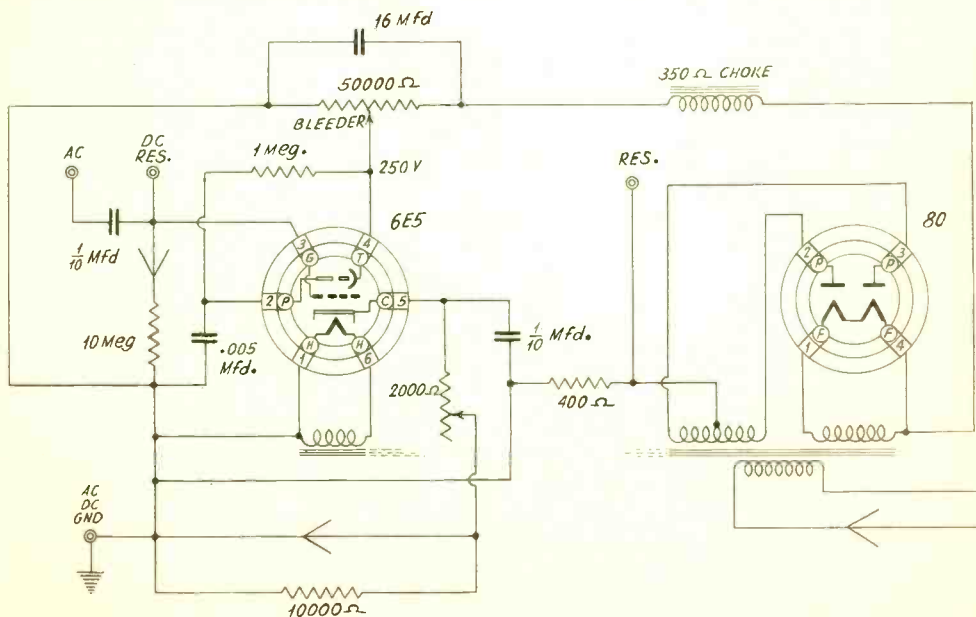

FIG. 4

The complete circuit, with rectifier.

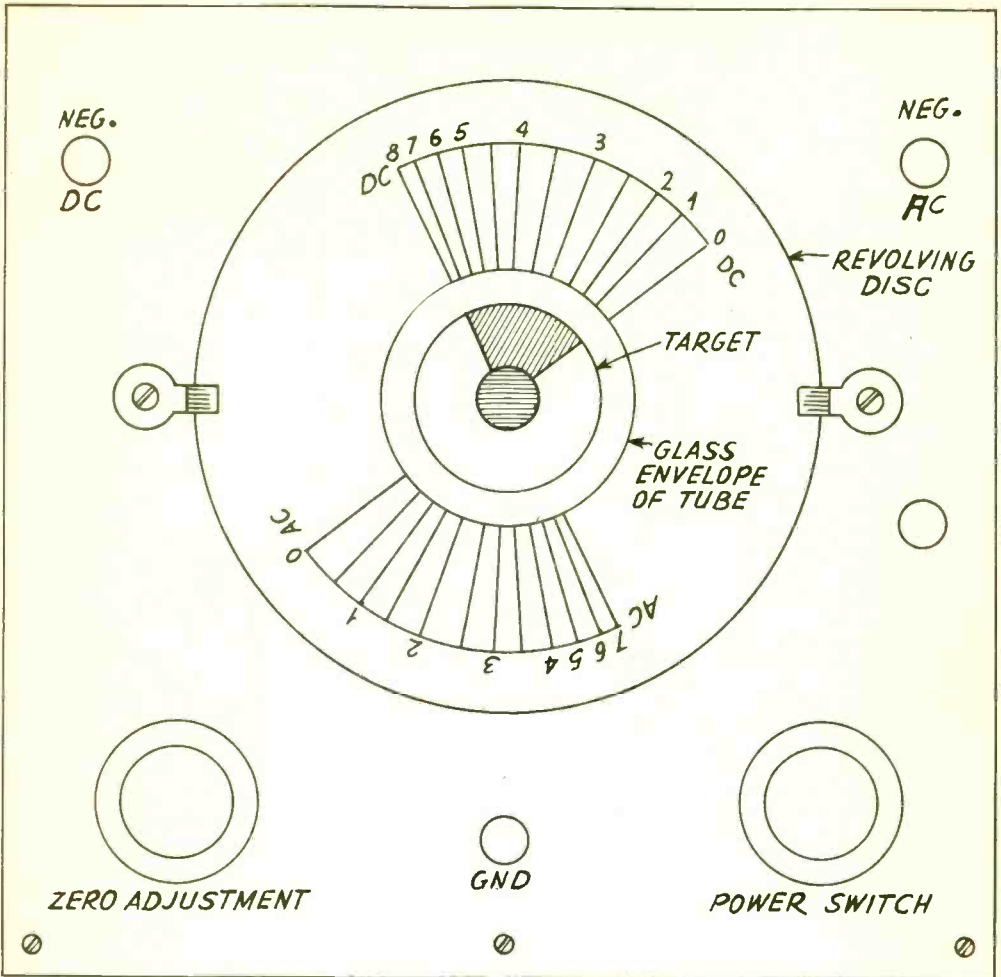
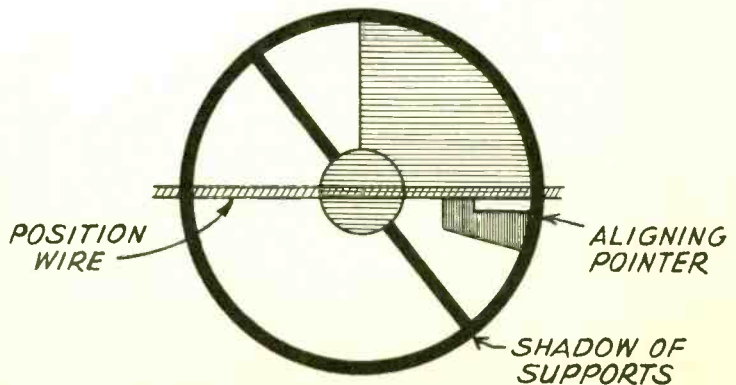

FIG. 5

In use the dial is rotated until the zero on the proper scale aligns with the radius of the proper shadow edge. The opposite shadow edge designates the scale value.

FIG. 6

Interposed in the line of sight is the aligning pointer, placed directly out from the glass envelope's dome. In making measurements the tube is rotated until the radius of the illuminated edge becomes tangent to the aligning pointer, as seen from the viewing aperture.



Removal of Hum on Short Waves

Occasional hum, heard during short-wave reception, is likely due to transmissions, over which one has no control, but a steady hum for all stations tuned in over the short-wave spectrum denotes a fault in the receiver. It is beyond the set owner's capabilities to remedy this defect, so a serviceman is called in. One method the repairman may use for hum location, so that proper remedy may be applied, is to disconnect the antenna, and with set going, measure with an output meter the quantity of response across the B supply, or any part of that supply. The output meter has a condenser in it that prevents d.c. from influencing the needle.

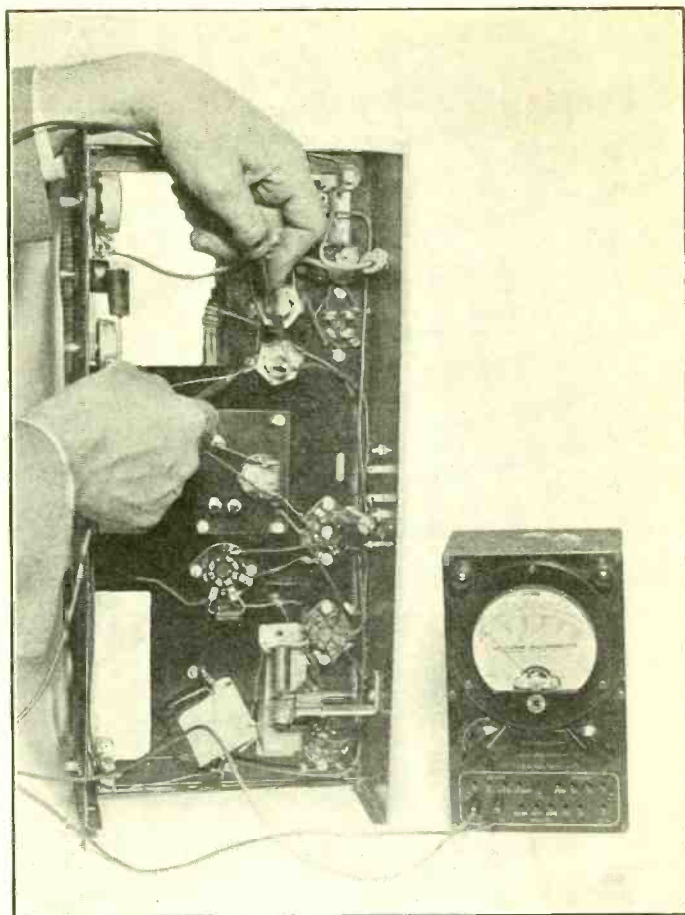

(Continued from page 36)

resistor in the cathode line of the tube, is applied to the tube when only a positive voltage is available for measurements, it then counteracting the negative supply.

Insulation to a high degree is demanded of all materials used as such, pin-jacks, etc.

Viewed in complete darkness, as it is, the fluorescent screen presents a pleasing and fas-

inating view. A heavy metal cabinet, grounded in use, adds to the voltmeter's stability, which is not affected by usual line voltage variations.

The constructor may easily duplicate this instrument in electrical and mechanical principles. Any geared dial mechanism of the correct ratio may be used and adapted to this layout with a few constructional differences. A hand-calibrated scale could be photostatted.

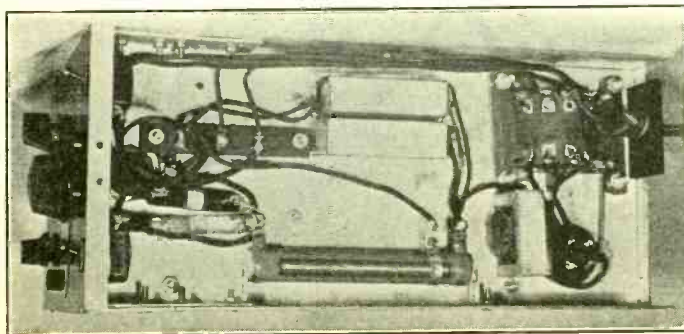
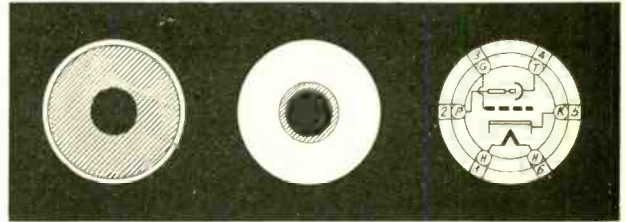

FIG. 7

Underneath view of the wiring of the ray-indicating voltmeter built by the author.

Unusual Indicator Tube, 6T5, Changes Lighted Diameter

Assuming the tube is connected with grid to negative of the control voltage, maximum signal spreads the illuminated area as a circle of light of increasing diameter. In the bottom-view diagram P = plate, T = Target.



Zero Grid Bias
(Min. Signal)

Max. Grid Bias
(Max. Signal)

Socket
Connections

THE 6T5 tuning indicator tube, recently announced by Hygrade-Sylvania Corp., differs from the 6E5 and 6G5 in the manner in which the shadow changes. The previous indicating tubes caused a change in the degrees of an angle, when influenced by the applied voltage, but the unusual feature of the 6T5 is that movement is as an enlarging or contracting circle. The greater the d-c voltage between grid and cathode, with negative to grid, the bigger the circle of light. The tube is for 250-volt operation and is not designed for 100 volts. The viewing surface is one inch diameter. The Sylvania announcement sets forth:

"The 6T5 differs from the 6G5 in that the visible indication is annular in shape. The lighted portion covers only a very narrow region at the periphery of the target when no voltage is applied to the control grid of the tube. When negative voltage is applied to the control grid the width of the fluorescent ring increases until it covers practically all of the target. Changes in annular width, or diameter of the shaded section, are more readily detected than are changes in the shaded angular sector when Type 6G5 is employed.

"In actual circuit use the varying negative voltage for controlling the shadow may be ob-

tained from some point in the a-v-c circuit, thus giving an indication of resonance when the unlighted portion of the target is at a minimum.

"Type 6T5 is mounted in a T-9 bulb on a standard small 6-pin base."

CHARACTERISTICS

Heater Voltage AC or DC	6.3 Volts
Heater Current	0.3 Ampere

OPERATING CONDITIONS AND CHARACTERISTICS

Heater Voltage	6.3 Volts
Plate Supply Voltage.....	250 Volts
Target Supply Voltage...	250 Volts
Plate Current (Triode Unit)*	0.24 Ma. Max.
Target Current	3.0 Ma. Approx.
Grid Voltage (Triode Unit) ^o	0.0 Volts
Grid Voltage (Triode Unit) ^{oo}	-22.0 Volts
Triode Plate Resistor.....	1.0 Megohm

*With triode grid voltage of zero volts.

^oFor minimum illumination of target.

^{oo}For maximum illumination of target.

Cunningham Quits As Head of RCA Mfg. Co.

David Sarnoff, president of the Radio Corporation of America, announced the resignation of E. T. Cunningham as president of its subsidiary, the RCA Manufacturing Company, Inc. Mr. Cunningham continues as a member of the RCA Manufacturing Company Board of Directors, and has been retained as counsel on production, sales and trade relations. In December, 1930, Mr. Cunningham sold his radio tube

company, E. T. Cunningham Company, to Radio Corporation of America.

The operations of RCA Manufacturing Company, Inc., will be under the direction of G. K. Throckmorton, executive vice-president of the company. Mr. Throckmorton has acted in that capacity for the past six years and will now assume the duties formerly exercised by Mr. Cunningham.

\$35,000 Amplifiers Put at 70 NBC Remote Controls

To raise the technical quality of remote control programs to the level of studio broadcasts, the National Broadcasting Company distributed to eight key points across the country seventy field amplifiers of a type newly developed by NBC engineers, it was announced by O. B. Hanson, NBC chief engineer. The amplifiers cost about \$35,000.

In carrying out the program, Hanson said, NBC will replace all its present field apparatus with newly standardized equipment. Distribution of the amplifiers is to be followed immediately by placement of 200 of the latest type microphones and 100 microphone stands among these divisions.

QUALITY AS FROM STUDIO

"Used in combination with new microphones," said Hanson, "this amplifier, which is the field equivalent of a studio control room, will put remote control programs on a parity with studio broadcasts. It is several years in advance of any now in use, and we believe it is the only one capable of transmitting without distortion every sound audible to the human ear—from the highest harmonics of the violin to the deepest of bass tones."

Perfect shielding from the common interferences that beset remote control broadcasting is obtained in the new amplifier by use of shell-type transformer cores and a special lightweight alloy case. NBC engineers have thus obtained perfect fidelity of the entire audio range from 30 to 15,000 cycles, and at the same time increased the amplification factor of the instrument to 100 decibels, a voltage gain of 100,000. This is fully fifty per cent. greater than that of amplifiers now commonly used.

WEIGHT 30 POUNDS

At the same time the weight of the amplifier has been reduced to thirty pounds through the use of the alloy case. Its four tubes of special NBC design have also permitted a great reduction in the weight of the battery unit. Filament consumption of the tubes is so low that in case of emergency the amplifier can be operated on a single dry cell.

The new amplifier has four outlets. Besides feeding the program through regular or emergency lines to the studio, it can supply public address systems, feed the program back to various pick-up points and supply the engineer's headphones or loudspeaker.

CLOSE TO THE IMPOSSIBLE

I find your magazine to be almost ideal from the experimenters' and students' viewpoint.

JOSEPH S. NABER,

11237 So. Albany Ave., Chicago, Ill.

FREQUENCY Uniquely Applied to a Generator



Harmonics are fruitful sources of resourceful measurement, but a complete understanding of their relationships, and how these may be used for various determination, sometimes requires outside help.

MANY servicemen possess signal generators that do not go as high in frequency as desired on fundamentals. Harmonics may be used but are attended by confusion, unless one applies a clarifying technique. One such general method is to measure the unknown in terms of two lower frequencies whose harmonics, or a fundamental and second harmonic, create consecutive responses in the unmolested receiver. It is not necessary to distinguish the orders. Then F_x , the unknown, equals the product of the two knowns divided by the difference between the two knowns. In symbols,

$$F_x = \frac{F_2 F_1}{F_2 - F_1}$$

where F_x is the unknown, F_2 is the higher of the two known frequencies, and F_1 the lower,

If it desired to work in steps of any particular value, say, 1 mc, which equals 1,000 kc, one may start always at 1 mc and measure given integral multiples of the starting frequency by calculating the points where the second responses come in. Terminal or near-terminal frequencies may be used for starts. Low-frequency ends are preferable for smaller frequency differences. Of the two responses the starting position is always one, and is always the same, the next consecutive response the other.

Suppose a band ends at 6.5 and 22.4 mc. It

EXTENSION

Harmonics Without Confusion

would be convenient to select either 7 or 22 mc as the working terminal. Now the problem is to find the second point.

For 14 mc obviously the first response is due to the second harmonic of 7 mc and the second to the fundamental of 14 mc. There is nothing heard in between in any case. If 14 mc is the unknown F_x , and the first position is F_1 for 7 mc, the second F_2 is related to $(F_x \div F_1) - 1$ for low-frequency terminal starting, or for high-frequency terminal, since the second fundamental will be lower instead of higher, the second response is related to $(F_x \div F_2) + 1$. The complete symbols are

$$F_2 = \left(\frac{F_x}{F_1} \right) - 1$$

where F_2 is the second response, F_x the unknown, and F_1 the low terminal starting frequency, a whole number near one end. The future unknown is treated as a known because assigned for the purpose of finding the second point. So F_2 is really the unknown in making the calibration. For starting at or near the high frequency end

$$F_1 = \left(\frac{F_x}{F_2} \right) + 1$$

where F_1 is the second response, F_x the unknown.

It is clear to mathematicians that from the foregoing the unknown in the measurement, or F_x , must be a multiple of the starting frequency. That is why the low-frequency terminal is preferred, for the gaps will be about one-third as great (7 mc apart instead of 22 mc apart), because harmonics of 7 mc instead of harmonics of 22 mc are used.

So, adhering to the low-frequency multiplier, say, 7 mc, since the unknowns F_x will be multiples, we could measure 7, 14, 21, 28, 35, 42, 49, 56, 63, 70 mc, etc., always in steps of 7. Although 14 and 21 appear fundamentally, we could include them on the new scale or band to be calibrated, as there is no harm in it, but we can not go indefinitely to higher and higher frequencies, as the curve is exponential, with spreadout favoring only low orders of harmonics, crowding affecting the higher orders.

The table herewith accepts 7 mc as the low-frequency terminal, but the same system can be applied to any other frequency, and the relative separations, for equal frequency span of fundamentals, will be about the same. First response is due to 7 mc, next consecutive response to integral multiples thereof, remember. The next

31,000 Postmasters Report Status of Rural Reception

Statistics on the age of receiving sets in rural districts, as well as broadcasting data, are being obtained in a new program service survey of the Federal Communications Commission. Post card questionnaires were sent by the Commission to the 31,000 fourth-class postmasters to get a typical cross-section of rural opinion. In the questionnaire the postmasters were asked if they have radio receivers and of what age. The returns are now completed and it is expected that the Commission will publish the results soon.

consecutive response just mentioned discloses the unknown receiver frequency, F_x :

Next Consecutive Generator Response (Mc)	Unknown Frequency (Mc) of Receiver
14.00	($\div 1$) = 14
10.50	($\div 2$) = 21
9.33	($\div 3$) = 28
8.75	($\div 4$) = 35
8.40	($\div 5$) = 42
8.10	($\div 6$) = 49
8.00	($\div 7$) = 56
7.90	($\div 8$) = 63
7.77	($\div 9$) = 70
7.70	($\div 10$) = 77
7.64	($\div 11$) = 84
7.58	($\div 12$) = 91
7.60	($\div 13$) = 98
7.50	($\div 14$) = 105

[The starting frequency for the above table is 7 mc. The unknown frequency is at right, the fundamental (second setting) used for disclosing the unknown is at left. In between are the divisors applied to the unknown to yield the fundamental.]

The accuracy depends primarily on the accuracy of the first frequency (F_1 or 7 mc), and not on the fineness of the second registration, assuming reasonable care in computation and registration. That is, the second position discloses the multiplier for 7, or divider for F_x , and the secondary reading, error could be due only to the wrong factor being applied. Of course, in terms of calibration, the application is indirect. The unknown is written in.

However, for the table the second harmonic of 7 yields 14, so reading 14 discloses 14, because $n = 2$ and $n - 1 = 1$, and as unknown, frequencies ascend, $n = 3$, and $n - 1 = 2$; $n = 4$, and $n - 1 = 3$, etc. Hence for all applications multiply F_1 by 2 and thus have the divisor equal 1, for 2 F_1 . And for successively higher F_x , in steps of F_1 , divide by 2, 3, 4, etc. This is done in the table for elucidation. It is a method original with me.

H. J. BERNARD.

Matching R-F Impedances With Uniform Transmission Lines

By J. E. Anderson

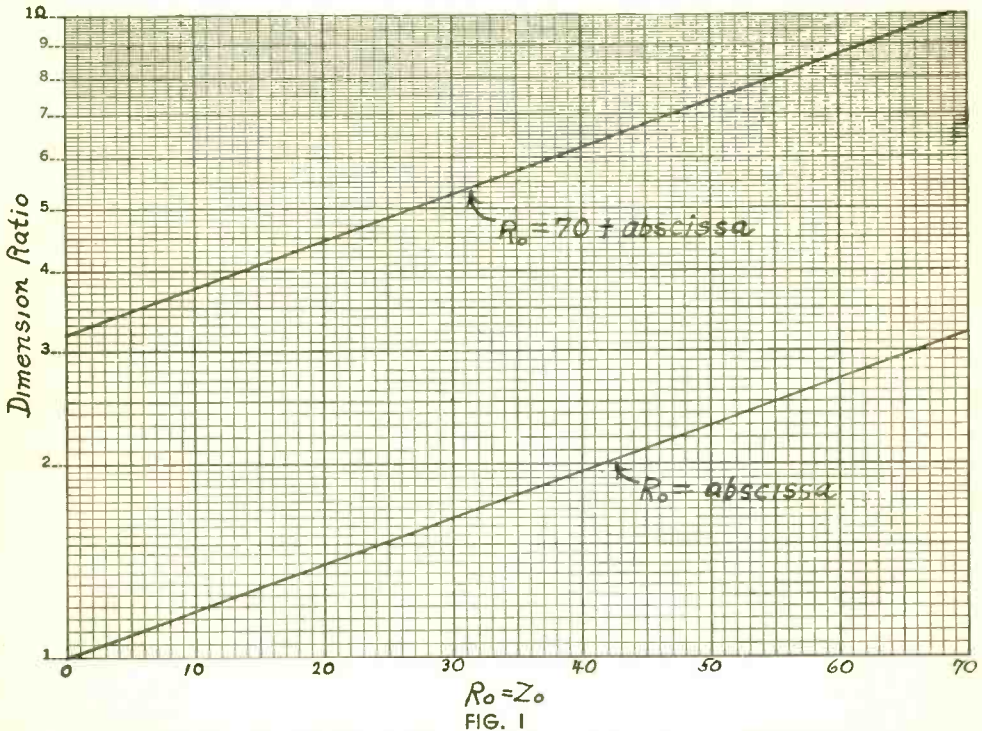

FIG. 1

Graph for finding the characteristic resistance of transmission lines. Abscissas give resistance directly for concentric lines. Double abscissa readings for parallel wire lines. Dimension ratio for concentric $R_0 \div R_{11}$, for parallel wire $2a \div d$.

THE most important property of a uniform transmission line is its characteristic resistance. The meaning of this concept is best explained in terms of a line of infinite length. Suppose the impedance of such a line is measured at the near end. If series resistance and leakage are negligible, the measured value will be a pure resistance. Now suppose a finite length of the line is cut off. The remainder is still infinite, and if the resistance is again measured it will be found to have the same value as before. Hence the resistance of the end of an infinite line will not change by cutting off finite sections. The resistance so measured is characteristic of the line and depends on the inductance and capacity per unit loop length of the line.

No physical line is infinite, of course. Every real line must be terminated. What, then, is the relation between the resistance of the in-

finite line and that of the finite length cut off? It is the same. However, it cannot be measured on the finite line without in effect making the line infinite. This is done by connecting a resistance at the far terminal equal to the characteristic impedance.

REFLECTION AVOIDED

As far as the effect on the measuring instrument at the near end is concerned, there is no difference between a resistance offered by a resistor and that offered by an infinite line of the same characteristic resistance.

When the near end of an infinite line is excited by radio-frequency energy there is no reflection from the far end, for there is no such far end. The energy travels on and on without limit. If the line is finite and is terminated by the characteristic resistance there is no reflection at the far end, either. The

energy is dissipated or used as fast as it arrives to the terminating impedance. In this case it goes on and on without limit, but it does so in a different form.

If the terminating impedance is different from the characteristic resistance there is reflection. This may be complete or partial. If the far end is shorted, the terminating impedance is zero, and all the energy is reflected. If the line is open at the far end, the terminating impedance is infinite, and then, too, all the energy is reflected. When the far end is open or closed, the impedance measured at the near end is a pure reactance, which may be either positive or negative and may vary between zero and infinity. In other words, the reactance may vary between minus infinity through zero to plus infinity.

LIKE A RESONANT CIRCUIT

A line which is one-quarter wave long and closed at the far end is equivalent to a parallel resonant circuit connected across the driver, and a quarter-wave line open at the far end is equivalent to a series tuned circuit connected across the driver. That is, it represents a short. The open line has an infinite impedance at the near end when the length is half-wave. For the same length the shorted line acts as a short circuit.

When the length of the line is just one-quarter wave the product of the two terminal impedances is equal to the square of the characteristic impedance. Thus if Z_1 is the impedance measured at the near end when an impedance Z_2 is connected across the far end, one-quarter wave away, then

$$Z_0^2 = Z_1 Z_2$$

In terms of a resistance-free line this becomes

$$R_0^2 = R_1 R_2$$

It is seen that the characteristic resistance of the line is equal to the geometric mean of the two terminating impedances.

LINE AS MATCHING DEVICE

This property of the quarter-wave line permits it to be used as an impedance-matching transformer. If the two terminating impedances are given, it is only necessary to design a quarter-wave line with a characteristic resistance equal to the geometric mean of the

two and then insert this line between the two resistances. An important application of this principle is the matching of the radiation resistance of an antenna with the impedance of a transmission line or with that of a source of radio-frequency energy.

The two impedances to be matched must be known by previous measurement before the matching line can be constructed, since the matching is done entirely by selecting a line of the required impedance. In case the line is of the parallel wire type, there is some chance of varying the impedance after the line has been constructed, for it is only a matter of varying the distance between the two conductors. Obviously, this is not possible when the line is of the concentric type. Yet the concentric line is superior to the other in that it does not radiate at all, whereas the parallel wire line does radiate a little.

As the characteristic resistance of a transmission line is so important, and as the computation of it is not easy without access to tables or a slide rule, a graph will come in handy. Such a graph is given in Fig. 1. The graph covers the case of the concentric conductor line. To get a large scale on a small sheet it has been broken up into two sections, one running from $R_0 = 0$ to $R_0 = 70$ and the other from $R_0 = 70$ to $R_0 = 138.5$. If the ratio of radii $R_2 \div R_1$ is less than 3.2 the abscissa scale gives the resistance directly. If the ratio of radii lies between 3.2 and 10, the abscissa scale gives the resistance if 70 is added. Suppose, for example, that the ratio of the two radii of the concentric line is 5. This comes on the upper section of the curve. The abscissa below the point reads 27. Hence $R_0 = 27 + 70 = 97$ ohms.

THE IMPORTANT RATIO

Now it may be that the ratio of the radii is greater than 10. In that case divide the number by 10, find the value of R_0 from the graph, and then add 138.5. If it is necessary to divide by 100 to get a number less than 10, add 277. In general, add 138.5 for each 10 by which the ratio must be divided to bring it below 10. The addition of 138.5 for each factor of 10 does not in any way affect the necessity for adding 70 to the abscissa readings if the ratio falls on the upper section of the curve.

(Continued on following page)

FIG. 2

This shows how a transmission line can feed directly into the grid circuit of a vacuum tube. The method is equally effective at all frequencies, if the tube input capacity is neglected.

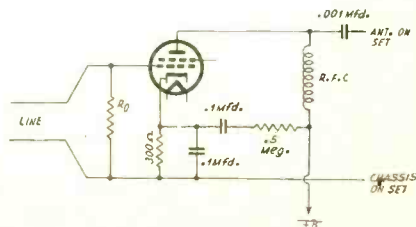

(Continued from preceding page)

As another illustration let us assume that the ratio of the radii is 600. To bring this down to less than 10 it must be divided by 100, or 10 twice. Therefore we must add twice 138.5, or 277, to the resistance. But the number is 6, and this falls on the upper section of the curve. Hence we add 70 more, making the total so far 554 ohms. The abscissa reading for 6 is 37.6. Hence the total resistance is 614.6 ohms. A concentric type transmission line is not likely to have a resistance anywhere near as high as that; but the graph can also be used for finding the resistance of parallel wire lines, which may have such high resistances.

The important ratio in the parallel wire type of line is $2a \div d$, in which a is the distance between the centers of the two parallel conductors and d is the diameter of each. Find

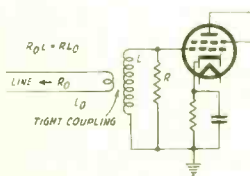

FIG. 3

The line is coupled to the tube by means of an untuned transformer. If the coupling is tight load resistance should be determined so that $R_0L = RL_0$ for matching. A voltage step-up is possible. This is subject to the limitations of all untuned transformers

this ratio for a specific case and from the graph find the resistance for the same ratio of a concentric line. Then double this and the result is the resistance of the parallel wire line.

To clarify this, let us work out a few examples. Suppose first that the diameter of each conductor is .145 cm and that the distance between their centers is 4.2 cm. The ratio sought is $2 \times 4.2 \div .145$, or 57.9. We first divide this by 10 and get 5.79. This falls on the upper section of the curve and the abscissa reading is 35.4. Therefore the concentric line resistance would be $138.5 + 70 + 35.4$, or 243.9 ohms. The parallel wire line resistance is twice this, or 487.8 ohms.

SUMMARY GIVEN

As a second example let us assume that the distance between the two conductors is 6 inches and that the diameter of each conductor is .04 inch. The ratio therefore is 12 divided by .04, or 300. Dividing by 100 we have 3, which falls on the lower section of the curve. The abscissa for 3 reads 66.2. To this we add twice 138.5, or 277. Hence the resistance of a concentric line would be 343.2. Doubling this we have 686.4 ohms for the parallel wire line.

Thus the graph in Fig. 1 can be used to find the characteristic resistance of any line, concentric conductor or parallel wire, regardless of the value of the dimension ratios involved.

Summary of procedure of using the graph: Find the dimension ratio of the line, $R_0 \div R_1$ for the concentric and $2a \div d$ for the parallel wire line.

Divide by multiples of 10 until the ratio is less than 10.

For each multiple of 10 add 138.5 ohms to the abscissa reading.

If the ratio less than 10 falls on the upper section of the graph, add an additional 70 ohms to the result.

If the line is of the concentric type, this is the characteristic resistance.

If the line is of the parallel wire type, multiply result by 2 to get the characteristic resistance.

Suppose we are required to design a parallel wire line with a specified characteristic resistance, using conductors of known diameter. How far apart must the conductors be placed? Let R_0 be the required resistance, a the required separation in inches, and d the known diameter of each conductor. The formula is $R_0 = 227 \log_{10} (2a \div d)$. Rewriting this formula to give a explicitly we have

$$a = .5d 10^{r/227} \quad (r = R_0 \div 227)$$

This formula can be used when logarithmic tables or a slide rule are available. Example: Let it be required to find a for a line of 600 ohms when $d = .04$ inches. Since R_0 is 600, $r = 2.168$. Hence $10^{r/227} = 1.47$ and $R_0 = 2.94$ inches.

END EFFECT IN LINES

A General relationship that holds for all wave motion is that the velocity of a wave is equal to the product of the wavelength and the frequency. While this is strictly true it often leads to wrong conclusions. The pitfall is that the velocity of a radio wave is not the same in free space as in other media, such as transmission lines and antennas, yet it is often assumed to be. A radio wave is always slower in lines and on antennas than it is in free space, and for that reason the wavelength is shorter in these media than in free space. Hence if a wave is measured on a transmission line and transferred to frequency by this formula $F\lambda = 300$, where F is in megacycles and λ in meters, the value of F obtained is too large. The error thus committed, however, usually does not amount to more than one-tenth per cent.

The actual percentage reduction in the velocity of a wave on a line depends on the damping factor per unit length of line. The reduction per unit of velocity, measured in free space, is $r \div 2\omega L$, in which r is the high frequency resistance per unit length, L is the high frequency inductance per unit length, and ω is 6.28 times the frequency. For practical purposes of determining lengths of antennas and lines the correction in the velocity is not necessary, but it should always be taken into account when lines are used for determining frequency through the measurement of wavelength.

There is another effect which is of much more practical importance, and that is the shortening of a resonant line as a result of non-

uniformity at the ends. The effective line is longer by a small amount than the physical line. Only open ends are involved in this.

A 5 PER CENT DIFFERENCE

Thus if the antenna is of the half-wave type and is center-fed, the antenna length is about $.95\lambda \div 2$ instead of one-half of λ . The reduction is about 5 per cent in this case. If the antenna is longer than half-wave the reduction applies only to the ends, so that if N is the total number of half wavelengths the antenna length is actually $(N - .05)\lambda \div 2$.

The effect is relatively greater for short waves than for long, for the non-uniformity at the ends is about the same no matter how long an antenna must be to make up half a wave or a quarter wave. The correction factor .05, therefore, is not a constant.

Antennas can be shortened and lengthened by means of condensers and inductances, respectively. These terms must be explained. An inductance in series with an antenna increases the wavelength to which it is tuned, so that for a wave of given length the actual antenna needed for resonance becomes shorter. When a condenser is put in series the effect is opposite. The wire needed for tuning to a given wavelength becomes longer. Thus a condenser "shortens" the antenna by making it longer, strange though that sounds, or the condenser fits an antenna of given length to a shorter wave.

MATCHING OF IMPEDANCES

Matching of impedances has come to mean to many a general panacea for all radio ills. It is supposed to be that magic something which makes tone in a receiver perfect, which eliminates noise when applied to an antenna, or which enables reaching out to the farthest corners of the earth with a one-tube set. These are some of the reasons why there is much demand for information on matching, not information leading to an understanding of the possibilities and limitations of matching, but practical information which will enable the recipient to coil up a few turns of wire, insert the coil in a receiver, and be assured of a perfect match under all conditions of weather, frequency, temperament, and the state of the Union.

Matching is a scientific means of getting optimum results out of the means available. It is a means for improving quality, for reducing costs, and for improving performance.

The teeter board found on all playgrounds for children is a good device for illustrating matching. Children three and four years old know what to do to achieve balance, and they arrive at the match by trial and error.

PROBLEM FOR GROWN-UPS

Now let us pose a problem for the adults. A teeter board is to be constructed with a fixed position for the fulcrum, not in the middle. Now, where should it be placed to that if any blond child takes the north end and any brunet child the south, the board will be in perfect balance. Matching impedance in radio is a matter of placing the fulcrum to achieve bal-

ance. The answer to the teeter board question is also the answer to the radio question, for the only difference is one of terminology. A true common answer might be that the problem is not soluble because there simply is no problem, only an admission of confusion.

SINGLE-FREQUENCY MATCHING

It is not possible to fix the fulcrum, or the ratio of transformation, when the impedances that are to be matched may vary from zero to infinity in either direction. The best that can be done is to compromise conditions within

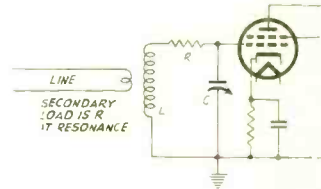

FIG. 4

The line feeds into a tuned circuit. When the circuit is in tune with the signal the secondary load is only the series resistance of the circuit. The primary should be of low inductance and the matching should be done by adjusting the coupling

a certain range of impedances. If the frequency varies, and that usually is the variable factor, the matching can be done for only one frequency. At all other frequencies within the band the matching will only be approximate.

What is the impedance of an antenna? It is the ratio of voltage to current at the point of measurement. This ratio varies from point to point on the antenna. If the current is maximum at one point, and the voltage therefore minimum, the impedance will be low. If the voltage is maximum and the current minimum, the impedance will be high. There is a gradual variation of the impedance between these points. If the energy is supplied the antenna at a low-impedance point, it is said to be current-fed. If the energy is supplied at a high-potential point the antenna is said to be voltage-fed. These nonsensical terms have become established by custom and are convenient. The antenna can be fed at intermediate points.

The radiation resistance of a half-wave antenna fed at the center (current-fed) varies to the distance of the horizontal wires above earth. The variation is from nearly 100 ohms at an effective height of .35 wavelength to 60 at .6 wavelength. As the height increases the fluctuation decreases and the resistance converges on 72 ohms as the distance becomes large. Since the effective height above ground is usually not large, there will be considerable variation in the radiation resistance.

A TWISTED-PAIR LINE

This could be allowed for very easily if the exact effective height were known. It is not
(Continued on following page)

(Continued from preceding page)

known, especially when the antenna is mounted on top of a building. Even when it is on top of a building of given height there is variation, for the resistance would depend on the height and nature of surrounding buildings. It is clear that there are conditions in large cities in which the top of the building is "ground." In other places the effective height of the antenna would be the actual distance from the wires to the street level.

72 OHMS FOR TWISTED PAIR

A transmission line made of twisted pair with No. 12 solid conductors has a characteristic resistance of 72 ohms. Hence such a line can be used advantageously for center-feeding a horizontal doublet. If the height of the antenna is such that its resistance is less or greater than 72 ohms, an adjustment can be made by spreading a few inches of the upper end of the line. If the antenna is tuned to 40 meters and the horizontal wires are high above the ground, there should be a spread of about 9 inches of the upper end of the feed line. This spread should take the form of an equilateral triangle, one end terminal of the line connecting to each quarter wave of antenna. The loss in the transmission line is not great for any reasonable distance that may be required to conduct the energy from the set to the radiator on the roof, or for conducting the energy in the opposite direction.

DIFFICULTY IN MATCHING

When a transmission line is brought to the receiver antenna coil it is difficult to obtain a match at this end. The resistance of the line, say, is 72 ohms. This is resistive and the load impedance should be a resistance of 72 ohms. The antenna could be connected directly across a grid leak of 72 ohms in the grid circuit of the first tube. But the connection should be balanced, for the line is balanced, since it is connected to the center of a symmetrical antenna. A transformer could be used between the line and the first tuned coil. If R is the effective resistance in the tuned secondary circuit, C is the tuning capacity of that circuit, L_1 the inductance of the primary turns, R_0 the surge resistance of the line, then the coefficient of coupling between the primary and second should be

$$k = (R_0 RC \div L_1)^{\frac{1}{2}}$$

for matching of impedances. It is noticed that R and C are variables and depend on the frequency. Hence the matching cannot be effected for more than one frequency. This should be for the same frequency as that for which the antenna doublet is tuned.

VARY COUPLING COEFFICIENT

Suppose that $R_0 = 72$ ohms, $R = 25$ ohms, $C = 100$ mmfd., and $L_1 = 5$ microphenries. What should k be for matching? The formula gives nearly .2. The proper adjustment can be made by varying the coupling coefficient.

Literature Wanted

Readers whose names and addresses are printed herewith desire trade literature on parts and apparatus for use in radio construction. Readers desiring their names and addresses listed should send their request on postcard or in letter to Literature Editor, Radio World, 145 West Forty-fifth Street, New York, N. Y.

- Rupert Electric Co., Rupert, Ind.
 Pelplain Radio Service, 1990 White Plains Ave., Bronx, New York City.
 Lynn Wilson, Heaton, N. D.
 L. M. Mick, 424 Second Ave., Dixon, Ill.
 H. B. Day, 2107 Livingston Street, Allentown, Pa.
 Universal Radio Service, 610 Dewey Ave., St. Joseph, Missouri.
 A. C. Martin, Box 38, Kings Mountain, Ky.
 Glen L. Bacher, Uncas, Okla.
 F. A. Munson, Repair Shop, Ashland, N. Y.
 Godfrey's Radio Service, 184 8th Ave., New York, N. Y.
 Jimmy Kelly, 208 Congress St., East McKeesport, Pa.
 Leonard Farnsworth, 900 Parsons Ave., Columbus, Ohio.
 Francis Weix, Superior Radio Service, Antigo, Wis.
 James Cuccia, 183 Lincoln Place, Garfield, N. J.
 S. G. Kurtz, Mifflinburg, Pa.
 R. N. Eubank, 2817 Montrose Ave., Richmond, Va.
 Robertson, 4019 Broadway, Huntington Park, Calif.
 C. R. Cannady, Box 92, Monett, Missouri.
 E. V. Coleman, Woodsocket, S. D.
 Sidney Multz, 9 W. 27th St., New York, N. Y.
 Bill Kiewel, 324 Grant Ave., Crookston, Minn.
 Linco, 212 Webber, Saginaw, Mich.
 H. R. Parker, 112 N. Fellows Avenue, Ottumwa, Iowa.
 J. C. Wunderlich, 502 East Webster St., Clinton, Illinois.
 John Bricker, Mantua, Ohio.
 V. M. Moen, Tracy, Minn.
 Paul Grayson, Gastonia, N. Carolina.
 G. Hayslette, Covington, Va.
 Tom Elliott, Deer Lodge, Montana.
 Joseph Napora, Uniontown, Pa.
 C. W. Nowell, Hagerstown, Md.
 J. M. Binding, Manistee, Mich.
 Norman E. Nelson, Clifford, N. Dakota.
 Barrett Radio, Sulphur Springs, Texas.
 Kenneth Conn, Mt. Union, Penn.
 Elder Barber, La Fayette, Ala.
 R. E. McKerral, Green Mountain, Iowa.
 L. T. Moore, 4039 Washington Ave., Fresno, Calif.
 Norman Nelson, Clifford, N. D.
 Matly J. Socha, 1958 Coney Island Ave., Brooklyn, N. Y.
 Stanley Schaaf, 4449 N. Damen Ave., Chicago, Ill.
 Frank Perry, 139 Lily Street, Paterson, N. J.
 Glen Nye, 1592 Front St., San Diego, Calif.
 C. V. MacLellan, Paramount Radio Sales and Service Co., 5712 Warren St., Detroit, Mich.
 Ben Wolf, Tremont Electrical Supply Co., 10 Boylston Street, Boston, Mass.
 Henry Sargent, 108 Hopkins Street, Brooklyn, N. Y.
 J. L. Davis, Radio Sales & Service, Basin, Wyo., Box 65.
 Joseph Turek, Jr., 6828 Windsor Avenue, Berwyn, Ill.
 William Hockin, 3622 N. Camac St., Philadelphia, Pa.
 Gordon Rosekilly, 4037 26th St., San Francisco, Calif.
 Power City Radio Co., 123 S. Main St., Sioux Falls, S. Dakota.
 Radio Distributing Co., 100 Selden Avenue, Detroit, Mich.
 Taylor Electrical Co., 201 E. Washington St., Madison, Wis.
 C. J. Swan, 1309 Broadway, Buffalo, N. Y.
 Kurt O. Kauffmann, Ph.D., 4 Park Lane, Mount Vernon, N. Y.

FORUM

DISFRANCHISED LISTENERS!

EDITOR, RADIO WORLD:

I HAVE read your publication for a considerable time with interest and pleasure. The articles appearing are in general well-written and provide an introduction to subjects of genuine importance. Occasionally, however, one notices an article written by someone whose interest and enthusiasm far exceed his qualifications. I refer specifically to the article titled "Device Lets Listeners Vote" in the April issue.

The naivete displayed in this article would be amusing if it did not also contain an element of irritation.

May we apply the idea to a hypothetical case?

Assume a metropolitan area, comprising roughly a population of, say, 2,000,000. To the utility, this will probably represent 500,000 customers of all classes, namely industrial, retail commercial, rural, residential, interconnected utilities, railways and others. A typical evening load of such a system might be 500 megawatts, and, contrary to Mr. Lumley's blithe assumptions, the power factor will not be unity, but probably in the neighborhood of .8 lag (we hope), meaning total of 625 mega v-a.

With units having capacities ranging from 50 to 200 mw each, the total connected capacity will surely exceed 700 mva. Of course, these figures would amuse an operator or supervisor of Brooklyn or Hell Gate, but this is only a hypothetical case.

We might conservatively estimate that the industrial portion of the connected load amounts to, perhaps, one-third the total, say 167 mw. Of this, a single large steel plant might quite possibly be using from 10,000 to 50,000 kw, this load being of an intermittent character, swinging aperiodically from a negligible amount to any intermediate value up to the peak.

Now let us suppose that three-fifths of the residential customers, or 300,000, each turned on a 60-watt lamp simultaneously. This is equivalent to a load change of 18 mw, and the system load, due to a single steel plant, is already fluctuating more than that. Then by the time we add perhaps two or more automobile plants, using inductor paint dryers, single-phase conduction or three-phase induction furnaces, I'm afraid Mr. Lumley's little 18 megawatts would be lost in the shuffle, as far as identification is concerned.

You see, Mr. Lumley, a switchboard instrument is so stupid that it can't tell the difference between a primary kilowatt and a residential kilowatt.

Now if one considers the reactance plan: first, the physical size of a condenser having sufficient capacitive reactance to make an appreciable difference would be of the order of 5-10 microfarads. Electrolytics won't do, unless we use the new a-c type. Have you priced them recently, Mr. Lumley? Also have you included in your calculations the effect, so far as substation meters are concerned, of (1) open-delta distribution banks and (2) induction regulators on distribution



feeders? You might just casually consider these.

The utility industry is technically trained, competent, conscientious in providing better service (including ever-narrowing tolerance on distribution voltage regulation). It is also long-suffering and patient. It has endured a plethora of Brisbanes, Boake Carters, Senator Norrises, et al, ad infinitum. Please do not let RADIO WORLD, an excellent publication, rush in where competent engineers tread cautiously.

NEIL E. HOLLINGER,
Detroit, Mich.

OLD-TIMER DISCRIMINATING

I have given up all other magazines but stick to RADIO WORLD, as it is "tops" on the small mechanical job. It helps me keep in touch with what is going on in radio.

THOMAS R. COMLY,
223 Sumpter St., Brooklyn, N. Y.

How to Use Meters

Their Application to D-C Measurements

By Bradley Argus

CONTINUITY TESTER

IF there is current flowing between two points there is a circuit. If a circuit is intended, but there is none, there is an open. If the circuit is closed there is a circuit but it may be a shorted one, meaning that the intended potential difference between the two points no longer exists. The open or the shorted circuit

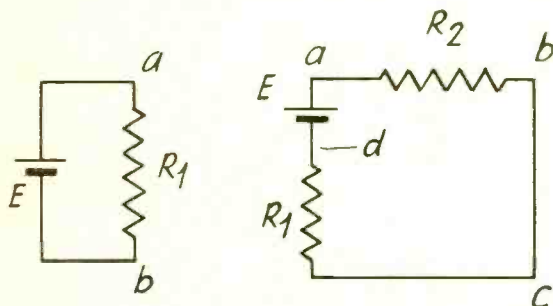

The resistor R_1 in the first diagram is connected across the voltage E . This is called parallel connection. Note that points a and b are common to the supply E and the load R_1 . In the second diagram R_1 is in series with R_2 , and this series circuit is in parallel with E . Also ER_1 and ER_2 are series circuits, across which are R_2 and R_1 respectively.

may be total or incomplete. For instance, instead of the complete open, or unlimited resistance, there is a measurable resistance, or instead of the complete short, there is at least some potential difference, though far below requirements. For convenience the distinction is not made usually between complete and incomplete shorts or opens. A circuit partly shorted is therefore called "shorted," and a path partly open is called "open."

Performance is marred or prevented when there is a short, and practically always defeated when there is an open. Hence a receiver that will not receive, or a transmitter that will not transmit, usually has either an open or a short. It therefore follows that a dead set commonly is the easiest one to service, as often only a single fault has to be located and repaired, and satisfactory operation is restored.

THE CONTINUITY TESTER

The basic circuit for determining whether a circuit is open consists of a source of potential connected to one side of an indicator, so that the other side of the source of potential and the other side of the indicator are used as free terminals. When these terminals are connected to an open there is no indication. When it is connected to a short there is an indication. The potential source may consist of a flashlight cell or battery. The indicator may be a pilot lamp. The device is called a continuity tester.

The word potential is used for describing the electrical pressure, or level, and is somewhat akin to altitude. The units in which potential is measured are called volts, comparable to feet in the altitude case.

Assuming that the voltage of the potential supply is equal to the voltage rating of the lamp, when the continuity tester is connected across a short the lamp will be at maximum brilliance, for in effect the two terminals of

the tester have been united. This would represent the example where E is the potential supply, often called voltage supply, in this example a cell; L_p is the pilot lamp. However, it is not quite correct to refer to this as an open "circuit," as there is no circuit when anything is open. In other words, all circuits are closed.

TESTED IN PARALLEL WITH CIRCUIT

The continuity tester should be connected in parallel with the unknown. This is called a shunt connection. The tester is directly across the explored unit. It is wrong to open the unknown and insert the continuity tester, as that puts the tester in series with the unknown.

The continuity tester conceivably could be of the kind that on a short gives a definite indication, and only that indication, but on an open gives none. But nearly all continuity testers give varying degrees of indication. The indicator may be any suitable device. Assuming it is a lamp, there will be various degrees of

E and the resistor are in series. The setup is open. To measure the current a meter is put between a and b and thus creates a circuit. The voltage across the terminals of E can be computed from the current and the sum of all circuit resistance,



illumination, depending on the resistance of the unknown. For instance, if the resistance of the external circuit is low compared to the sum of the resistances of the lamp and the battery or cell, then the illumination will be almost as bright as if there were a short, and it would be hard to distinguish between the two examples.

If the resistance of the unknown is fairly large the lamp will light less brightly. This is true because the resistance of the external circuit has been added to the others, and being large compared to the others, reduces the current to a large extent. Hence the continuity tester gives relative values, though unrecorded

AMMETER

It is hardly possible to obtain lamps that glow fully at less than the voltage of a single cell, which is about 1.5 volts, therefore the lamp as indicator has limitations. Unless used for definite purposes, where the unknown resistance is low, or where the main purpose is to disclose shorts, the lamp is best supplanted by a meter.

A meter is a measuring device that is calibrated. If the calibration is in relative values

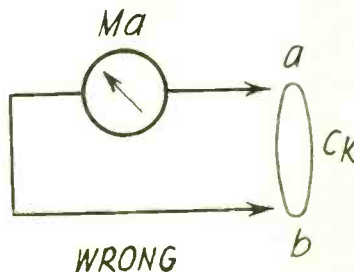
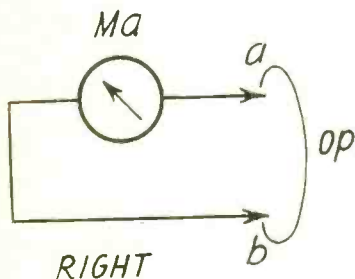

For current measurements the meter *Ma* serves to close the open. The points *a* and *b* therefore represent a discontinuity in the setup to be examined. It is wrong to put a current meter across a closed circuit, for that is a voltmeter connection, and the meter needs protection it lacks (series resistor).

ones. By checking two units of considerably different resistance values, one could determine, by memory of the amount brightness or dimness of illumination, that one unit had much more resistance than the other, the bright illumination disclosing the low resistance, the dim illumination the relatively high resistance.

CONFUSION AVOIDED

So high may be the resistance of the unknown that not enough current flows to light the lamp at all. Hence the result of this test might be considered as disclosing an open. In fact, however, the circuit exists, there is a closure and not an open, and the continuity tester has failed to distinguish between the two.

Therefore the continuity tester is limited by its sensitivity. A person is referred to as being sensitive when he takes offense very easily. A remark of small consequence would cause a reaction of a high order. The same general idea is applicable to instruments. Sensitivity is a measure of how small an impulse or current is necessary to give full-scale deflection.

In measuring test and measuring instruments the sensitivity is therefore a measure of the smallest cause necessary to produce a given effect. Always the meter needle is assumed at maximum deflection in considering this rating. The cause is always current flow, in instruments that draw current. In a lamp it is maximum brilliance, or maximum power. In a current-drawing meter it is always full-scale deflection, where the needle points to the maximum position, usually to bar at extreme right.

the meter is called a galvanometer. Thus, the graduations may be from 0-30 or 0-50, and while the deflection may be proportionate to the current, no particular value of current is assigned to any setting. If the current is known for one setting, however, it would be known for all, as d-c meters are linear, i.e., response is proportionate to current. When values are assigned they are in amperes, milliamperes, microamperes, or micro-microamperes. Each successive term represents one one-thousandth of the current of its predecessor. Thus, one milliampere is one one-thousandth of an ampere, one microampere is one one-millionth of an ampere or one one-thousandth of a milliampere, and one micro-microampere is one thousand-millionth of an ampere, or one millionth of an ampere.

WORKS ACROSS HIGH RESISTANCE, TOO

When a more sensitive instrument is used, and assume that the same cell is included as served the pilot lamp, since the current for maximum deflection of the meter needle is much less than that required for maximum brilliance from the lamp, a limiting resistor may be required. This resistance would be of such value that application of the cell potential would cause fullscale deflection, as for instance when the unknown unit is shorted.

The short test is made just as well as in the example of the lamp. The open test is extended

(Continued on following page)

(Continued from preceding page)

to far greater usefulness, as even when the unknown is a high resistance, enough current may flow through the meter to register an indication. This need not be full-scale or even nearly so.

For a 0-1 milliammeter, popular in radio testing and measurements, a current as small as 20 microamperes can be easily read, usually at the second division of the meter calibration,

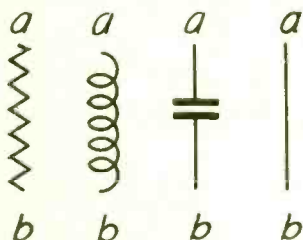

The continuity tester will check a resistor or coil for continuity, but condensers are practically always open to d.c., while a short may be checked for any circuit.

the first bar representing zero. By estimating between the first and the second divisions current can be read at the half-way position at 10 microamperes. So small a current as 10 microamperes, one-one-hundred thousandth of an ampere, would not have caused the slightest indication in the pilot lamp.

Therefore with a sensitive meter even circuits of relatively high resistance will give an indication, because of some movement of the meter needle, whereas in the example of the lamp, the high resistance gave the same indication as an open.

OHM'S LAW

If all resistance in a circuit is known, and the applied voltage is known, the current may be computed by Ohm's law. Or, if the current is read on the meter, and the voltage is known, the resistance may be computed. Or, if the resistance and the current are known, the voltage may be computed. The equation relating voltage, current and resistance is known as Ohm's law. Its three forms follow:

$$\begin{array}{l}
 \text{curr in amp} \quad I = \frac{E \text{ volts}}{R \text{ Res}} \\
 \text{V} \quad \quad \quad E = IR \quad \text{c} \times R \\
 R \quad \quad \quad R = \frac{E}{I} \quad \text{V} \div \text{cur}
 \end{array}$$

where I represents the current in amperes, E the potential in volts and R the resistance in ohms.

Let us consider the first form. I is the current

and is unknown. The equation states that if the known voltage is divided by the known resistance, the answer is the current. Therefore the higher the voltage (resistance being held constant) the higher the current, because a higher number is being divided by a fixed number. Also, the higher the resistance (voltage constant), the smaller the current, because a fixed number is being divided by a higher factor than previously, yielding a smaller result. The first form, for current, therefore is solved by division.

SENSE OF DIRECTION

Take the second form. This solves for voltage when the current and the resistance are known. The voltage in volts equals the product of the current in amperes and the resistance in ohms. The higher either the current or the resistance, or the higher both are, the higher the voltage will turn out to be. The second form, for voltage, is therefore solved by multiplication.

In the third form the resistance in ohms is found from known values of voltage and current. The smaller the current, the higher the resistance, because the voltage (held constant) is divided by a larger number, and the result necessarily is smaller. The smaller the voltage (resistance constant) the smaller the current, because a smaller number is divided by a fixed number. The third form, for resistance, like the first form for current, is solved by division.

Whenever "the higher, the higher" applies, so does "the lower, the lower." For instance, the lower the current or resistance, or both, the lower the voltage.

Certain other similarities exist. In the two forms, for current and resistance as unknown, where division is applied, it is the voltage that is divided by something. For current determination the voltage is divided by resistance.

MEMORY HELP

For resistance determination the voltage is divided by the current. It is helpful to remember there are only three things to consider: current, voltage and resistance. For current and resistance as unknowns, the voltage is divided by something. If current is the unknown, then the voltage, being known, is divided by the only other possible constant, known or unknown, in this case resistance. If the resistance is the unknown, the known voltage is divided by the third constant, the current. So, since the two knowns are to the right of the equal sign, for the known voltage is always divided by the third quantity, which is known, also.

The multiplication example is perhaps simplest because it is in a form not found in the others and is most easily remembered. Therefore as a memory guide, first learn the equation for unknown voltage ($E = IR$), then memorize the current formula ($I = E \div \text{the third factor}$) and then the resistance formula ($R = E \div \text{the third factor}$). When you have I and E the third factor is R. When you have R and E the third factor is I. Soon it will be easy to bear in mind the formulas as given in the column at left.

NEW PRODUCTS

Two New Oscilloscopes by Supreme, 2" Tube

Supreme Instruments Corporation, Greenwood, Miss., announces two models of oscilloscope using the new two-inch tube. Model 535, the larger, can be used as a complete visual servicer in conjunction with a frequency-modulated signal generator. It employs return sweep eliminator for completely removing high-frequency linear sweep return. Also it provides selective return sweep eliminator for inclusion or rejection of power supply frequency return sweep. Positive interlocking circuit between

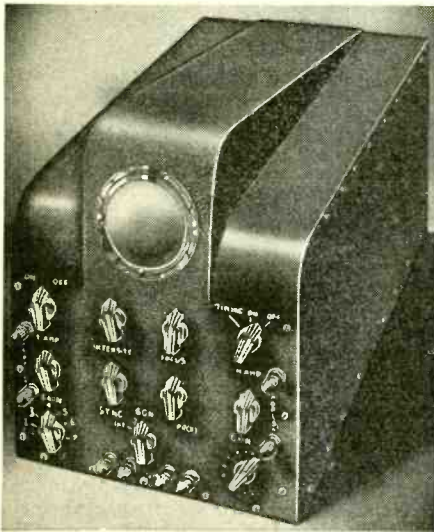

Supreme also uses the 3-inch tube, as in Model 545 above.

linear time base and incoming signal is provided. Special uni-control allows both horizontal and vertical spot centering both knobs on panel but using only a single shaft protrusion. Horizontal and vertical amplifiers are included. Means for controlling gain in two amplifiers, linear time base (saw tooth) oscillator from 15 to over 30,000 cycles, special switching systems for routing incoming signals direct to cathode-ray tube or through amplifiers, intensity and focus controls, antique bronze panel and in golden oak carrying case with handle, small size and light weight, are the other features.

Model 530, the smaller, has selective return sweep eliminator for inclusion or rejection of power supply frequency return sweep. It may be used for visual alignment with a frequency-modulated signal generator. Particularly adapted to use by amateurs for transmitter

adjustment, it employs vertical amplifier, graduated gain control, uni-control potentiometers, intensity and focus controls, special switching circuits, and is mounted in antique bronze panel and in golden oak carrying case with handle.

Webster Offers Four Office Communicators

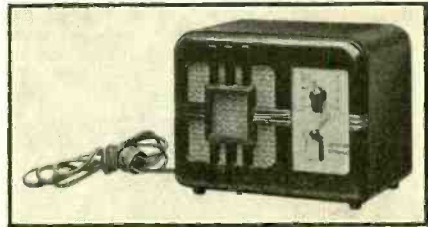

Model OCM inter-office communicator, known as the Applcall and manufactured by Webster.

The Webster Company, 5622-5708 Bloomingdale Ave., Chicago, Ill., now has four inter-office communication arrangements:

(a) (Two station) one OXS and one OXM unit. Strictly an inter-communicating system.

(b) OXC master and OXM outlying stations. Strictly an inter-communicating system, utilizing one amplifier at the central location and may be employed with as many as ten outlying stations.

(c) Two OC units. An inter-communicating system for 2-station installations only. Utilizes two amplifiers (differing in this respect from System A), making it possible for either station to call the other even though the switch at the location called may be "off", a feature not available in System A.

(d) Three or more OCM units.

Clarostat Adds Tapped Replacement Controls

A complete assortment of tapped control replacements, in handy kit form, is being offered by Clarostat Mfg. Co., Inc., 285 N. 6th St., Brooklyn, N. Y. There are fourteen units in the kit, or one of each of the types taking care of past and present production of sets.

This assortment of tapped controls permits the immediate replacement of any defective tapped control, with the full assurance that total resistance and tap ohmages satisfactorily match original values, since they have been decided upon only after an exhaustive survey of existing set requirements. Further details regarding the tapped control, metal-tube resistor, and other exact-duplicate replacement kits, may be had by writing to the company's Dept. R.W.

Features Are Added To Weston Tube Checker

A new radio tube checker of unusual operating flexibility, designed as a "matched companion unit" for the 772 Weston, a 20,000 ohm-per-volt Analyzer, has just been introduced by the Weston Electrical Instrument Corporation, Dept. RW, Newark, N. J. Equipped with a large rectangular indicating meter "stepped up" from a two-color metal panel, this Model 773 tube checker is equally striking in appearance and convenient in use. If desired, the two test units may be purchased in a single combination carrying case

ble sputtering, "frying" or other tube noise in any or all electrode circuits. A hot-cathode leakage test is provided, and the neon short check can be quickly made while the tube is hot to catch intermittent shorts. A direct reading line-voltage reading on the 4½" meter can be made through a toggle switch at any time while the tube is under test.

COLOR BAND MARKING

The 4½" meter scale has a color band-marking clearly differentiating between good and bad tubes. Operating controls and trim on the panel stand out in brilliant red and chromium against the glossy black background. Carrying cases for the portable units (either the checker alone or the combination checker-



Model 773, at left, for combination with 772 Analyzer, or, at right, as individual portable unit.

designed for the purpose. Or, as an individual piece of equipment, the tube checker is available with carrying case or special counter mounting.

IS ANTI-OBSOLEScent

The new checker features the same "anti-obsolescence" circuit and switching system first introduced in the Weston Model 770 tube two years ago—a system still capable of testing the newest tubes without adapters or other modifications. In this circuit, total emission tests on various types of tubes are made on a specific load basis, reflecting service conditions for (1) general type tubes, (2) battery-operated tubes, and (3) diodes, and eliminating all possibility of tube damage. However, the selector switches and inter-electrode switches which permit all elements of each tube to be individually checked have been relocated for maximum operating convenience. Tube sockets, including a spare for possible new tubes, are also grouped for extra convenience in use.

A new feature of the unit is the "noise-test" jack, where headquarters or amplifying unit may be plugged, if desired, to check on possi-

ble sputtering, "frying" or other tube noise in any or all electrode circuits. A hot-cathode leakage test is provided, and the neon short check can be quickly made while the tube is hot to catch intermittent shorts. A direct reading line-voltage reading on the 4½" meter can be made through a toggle switch at any time while the tube is under test.

COUNTER MODEL

For the counter, an angular mounting base, also of polished wood, gives the tube checker a substantial appearance without needless waste of counter space. An outstanding feature is the rotator-type reference index covering all types of tubes in current use, so arranged in the base that tube-test data is instantly brought into view beneath a glass-covered opening. This index also utilizes the exclusive "key-number" classification system. A revised listing can be easily substituted for the current edition should new tubes be introduced in the future.

Small Oscilloscope, Sweep Oscillator, by RCA

Two new pieces of test equipment have been introduced by the RCA Parts Division in the form of a \$47.50 cathode-ray oscillograph, using the 913, and a greatly improved electronic sweep test oscillator, adaptable to all types of cathode-ray oscillographs in circuit alignment applications and which eliminates the need for a separate frequency modulator.

Among the oscillograph's features are high sensitivity, providing a full visual image while using only 1.75 volts (rms); vertical and horizontal amplifiers, with individual controls, in a flat range of from 30 to 10,000 cycles; linear timing axis in the same range; small spot diameter for sharp focusing, and individual centering controls. It utilizes five tubes, and has an input power consumption of 50-watts cold and 30 watts hot. The 913 has a one-inch screen.

The new RCA electronic sweep test oscillator incorporates a number of outstanding advantages over previous apparatus of this type. A-c operated, it is made for every application in which a wide-frequency-range test oscillator is needed. It may be used with all types of cathode-ray oscillographs in alignment applications. The new oscillator is particularly valuable in servicing receivers of the high-fidelity type having flat-top i-f stages, which cannot be properly adjusted with an ordinary output meter. High output, negligible leakage, variable-width frequency modulation, and a sweep rate of 120 times per second which eliminates flicker are some of its many features. An easy-to-read 4-inch dial, rotating 340 degrees, spreads the six fundamental frequency ranges over a total scale length of 45 inches. Other specifications are five tubes; frequency range of from 90 to 32,000 kilocycles; output control has three-step attenuator plus continuously variable control; dimension 13 $\frac{3}{4}$ " in length, 9 $\frac{1}{4}$ " high, 7 $\frac{1}{2}$ " deep, and weighs 17 pounds.

Both pieces of test equipment are almost identical in size and external appearance. The cases are attractively finished in gray wrinkle lacquer with nickel trimming, reversed etched, nickel-silver panel and have large, soft rubber feet.

New Line of Speakers Announced by Oxford

A complete line of permanent magnet speakers is announced by Oxford Tartak Radio Corporation. "Permag" has been adopted as the trade name for these speakers.

This line comprises speakers ranging from 3" to 14". The 3" speaker is being featured as "the world's smallest permanent magnet dynamic speaker." This speaker is expected to be very popular in small a.c.-d.c. sets and inter-office communicating systems.

In addition to the 3" Permag, Oxford has

developed a trumpet type permanent magnet speaker with a 6" cone housing for use with an exponential horn. It is claimed that this is superior to a dynamic unit with standard field coil excitation.

For automotive and portable installations, the Permag Trumpet opens an entirely new

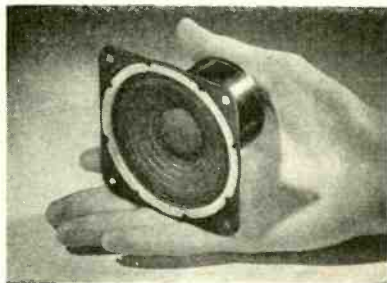

The hand is shown to give a good idea of the "Permag's" comparative size.

field, since no external field excitation is required.

Oxford states that a new spun aluminum exponential horn, model XA22, is now available for use in connection with their "Permag Trumpet" or standard dynamic trumpet. Detailed information will be furnished upon request to J. S. Gartner, Dept. RW, Oxford Tartak Radio Corporation, 915 West Van Buren Street, Chicago, Ill.

Specifications Issued On New C-D Condensers

Specifications on the new type TL capacitors are now available in Cornell-Dubilier's catalog 135A. The type TL's are high-voltage paper condensers, impregnated and filled with Dykanol. These capacitors, conceived and recently developed in the laboratories of the Cornell-Dubilier Corporation, are extremely compact, yet retain the excellent characteristics of the more bulkier types. They are especially suited for power supplies and high fidelity amplifiers. Address requests for Catalog 135A to Dept. RW, the Cornell-Dubilier Corporation, South Plainfield, N. J.

Shiepe's New Generator Shorts Out Unused Coils

Edward M. Shiepe, who designed test oscillators for other manufacturers until he became manager of Delta Radio Company, 135 Liberty Street, N. Y. City, has brought out a new signal generator under the Delta name, covering from 50 kc to beyond 30 mc, all on fundamentals. Three 6C5 tubes are used. There are six switch bands. At any one setting the switch shorts out the five other coils. A circular is obtainable from Dept. RW.

South Bend Adds Series of Silent-Working Lathes

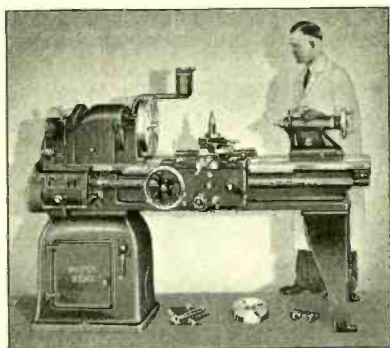

A new, silent lathe by South Bend.

The South Bend Lathe Works, South Bend, Indiana, announce a new line of back-gear, screw cutting, precision lathes in the new Underneath Belt Motor Drive. The new series of lathes are offered in 9-in., 11-in., 13-in., 15-in. and 16-in. swing, and in bed lengths from 3 ft. to 12 ft.

The new underneath belt motor drive is unusually compact and is silent, powerful and economical in operation. The motor and driving mechanism are fully enclosed in the cabinet leg underneath the lathe headstock. There are no exposed pulleys, belts, or gears and no overhead belts or pulleys to obstruct vision or cast shadows on the work.

The belt drive is the outstanding feature, as it is silent in operation and provides a smooth steady pull free from vibration and chatter. Power is transmitted from the motor to the countershaft by V-belt, and from the countershaft up through the lathe bed to the headstock cone pulley by a flat leather belt.

The company is issuing a new catalogue, No. 96-RW, containing descriptions of these lathes with accompanying illustrations giving valuable instructions on lathe practice and operation. Any reader interested in securing a free copy may write to Dept. RW, South Bend Lathe Works, South Bend, Indiana.

Midwest Seeks Men for Official Service

The Midwest Radio Corporation is building up a radio servicemen's organization to serve their scores of thousands of customers all over the country.

Competent servicemen are welcome who can not only make the original installation of Midwest Radios on a fee basis, which the Midwest Radio Corporation will pay, but to whom Midwest customers can be referred in their respective neighborhoods for service at all times. Servicemen, who are interested, should write to Dept. RW, Midwest Radio Corporation, Cincinnati, Ohio, for complete details.

ICA Produces Two New Car Antennas

Two new car antennas designed to meet all automotive-radio requirements are announced by Insuline Corp. of America, 25 Park Place, New York, N. Y. The first is the ICA "Poletenna," which is of the telescopic type, opening to a maximum height of 8 ft. It is intended to clamp to the rear bumper, and fits any make or model of car. It is also suitable for transmitting purposes and can be tuned for 5- and 10-meter amateur operation.

The second new antenna is the ICA "Airflow," especially designed for new cars of the streamline and all-steel body types. It consists of a length of rust-proof metal tubing supported on the top of the car by means of rubber suction cups, and is installed quickly and easily without requiring drilling of the top. It provides maximum signal pick-up with minimum ignition noise and wheel static, and is not affected by rain, snow, dirt or mud. In addition, it is attractive in appearance.

The list price of the ICA "Poletenna" is \$2.50; of the "Airflow," \$3.00. Both products are available from dealers and jobbers.

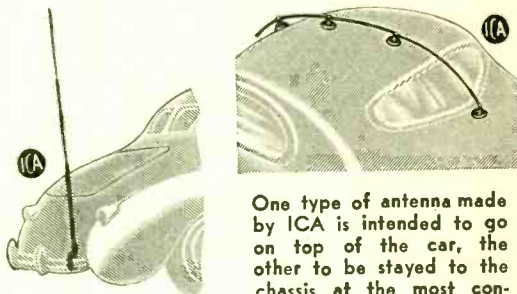

One type of antenna made by ICA is intended to go on top of the car, the other to be stayed to the chassis at the most convenient or effective place.

G.E. Makes a Double Photoelectric Recorder

A photoelectric instrument which will record simultaneously on one chart two electrical quantities as low as one microampere, full scale, and representing a power consumption of only 0.00000001 watt from the measured circuit, has just been placed on the market by the General Electric Company. It is designated the double photoelectric recorder.

The double photoelectric recorder can be applied wherever simultaneous readings are desired. In some cases this immediately cuts testing time in half and in others it aids materially in discovering unusual relations between two variable electrical quantities. This recorder is the outgrowth of the original photoelectric recorder which has become familiar to electrical and mechanical engineers, physicists, and others, including physicians, and scientific crime-detection specialists.

Vari-Volt Transformer Big Aid on the Bench

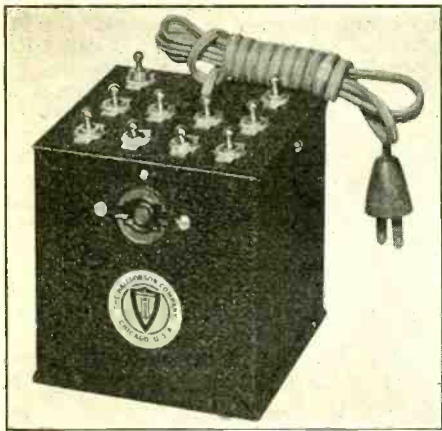

Halldorson Vari-Volt Transformer.

A handy adjunct for the service bench is a new transformer made by the Halldorson Company, Dept. RW, 4500 Ravenswood Avenue, Chicago, Ill. It may be used for adjustment of live voltage, also for selecting 0-236 volts in two-volt steps or 0-128 volts in one-volt steps. Power is 250 watts.

Two Meter Kits by Radolek, 20,000 O-P-V

"The new trend in servicing instruments is definitely in the direction of higher sensitivity," says an announcement by the Radolek Company. "The jump from low resistance to 1,000, to 2,000 and now to 20,000 ohms-per-volt instruments shows the service instrument manufacturers reply to the servicemen's demand for sensitivity. But the rise of highly-sensitive meters was not purely impulsive on the part of the servicemen. It resulted from the development of new circuits calling for more accurate adjustments and forbidding any excessive current drain during the tests."

Radolek announced an analyzer kit, including the Radolek-Simpson meter, housed in an attractive bakelite case, 4½ x 4 inches with clearly marked scales. Two similar models are available. The first consists of a meter and resistors mounted on a subpanel for d-c measurements only. The second model consists of a meter, all resistors and other accessories for both a-c and d-c measurements.

"This highly-sensitive set tester," the company adds, "will permit all standard tests possible with other instruments and besides will allow the analysis of a.v.c. and a.f.c. circuits and will measure diode circuit current, the actual voltage on the plate of high- μ triode, the

oscillator grid current, and many other values that cannot be tested accurately with ordinary instruments."

The resistors and other accessories are supplied mounted on the subpanel. The complete assembly and wiring is simple and may be completed in a couple of hours. Complete details are available from Dept. RW, The Radolek Co., 601 West Randolph Street, Chicago, Ill.

Hammarlund Transmitting Condensers Low-Priced

A new series of transmitting condensers for high-frequency and ultra-high frequency, both medium and low powered units, has just been developed by the Hammarlund Manufacturing Company. Though low in price, these condensers include all the constructional features required in quality transmitters of all types.

Known as the MTC series, they are available in both single and split stator styles in 19 different sizes with capacities ranging from 20 to 530 mmfd. and with breakdown voltages from 1,000 to 6,000 volts.

The end frames are of heavy aluminum sheet, while the rotor and stator plates are of heavy aluminum, firmly anchored in place by wedging into deep slots and then by further staking. An accurately-ground stainless steel shaft is carefully fitted to a long bronze front bearing

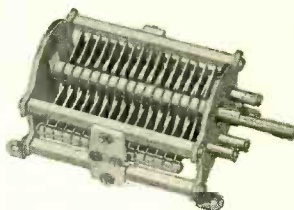

New type Hammarlund transmitting condenser. Static due to friction formerly was a bugbear in auto set servicing. Now wheel static is prevented by killing the insulation between metal wheels and stationary axle. Cone brass spring rides the cap and axle.

mounted on a beryllium cushion disc. The free floating action thus afforded provides for a perfect bearing and consequently smooth operation. The rear bearing is of the steel ball and cup type. Thorough Isolantite insulation and a silver-plated beryllium contact wiper assures lowest losses, lowest series resistance and noiseless operation.

The condensers are designed for either panel or base mounting and range in size from 4" long to 6¼" long including a 1" long shaft. Plates are either round edged or standard type, thickness ranging from .025" to .040" and from .031" plate spacing to .171" plate spacing, dependent upon voltage breakdown required.

Complete technical bulletins are available by addressing Hammarlund Mfg. Co., Dept. RW, 424 West Thirty-third Street, New York, N. Y.

Dual Voice Coil in RCA Fidelity Speaker

BY A. K. WARD

Commercial Sound Engineer, RCA Manufacturing Company

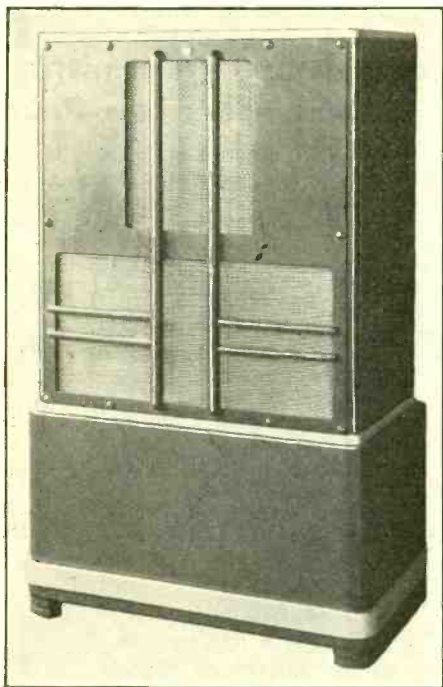

Front view of the new RCA high-fidelity speaker.

To fulfill the most exacting requirements for true high-fidelity sound reproduction, the Commercial Sound Section of the RCA Manufacturing Company has announced the development of a special console cabinet loudspeaker. The outstanding performance characteristics of the new console speaker make it particularly applicable for use as a high-fidelity monitoring speaker by the large broadcasting stations, as well as for music rooms, classes in music appreciation, hotel-lobbies and wherever life-like reproduction with the utmost fidelity is a factor of importance.

This unit can be obtained with or without a power amplifier. The illustration shows the unit complete with the base for housing the power amplifier. The speaker has a substantially uniform frequency response range of from 60 to 10,000 cycles. Variations allowed in the manufacture of this unit are plus or minus 6 db., whereas it has been shown on test that the average curve is well within plus or minus 5 db.

This loudspeaker is not just simply a loudspeaker in a box, but the speaker itself is a special double voice coil mechanism designed for equal reproduction of high and low frequencies. By constructing each portion of the cone driving mechanism for its reception part

(Continued on page 58)

New Dumont C-R Tube, 2-Inch Size, List, \$7.50

A two-inch cathode-ray tube, type 24-XH, has just been announced by Allen B. Du Mont Laboratories, Inc., Dept. RW, 532 Valley Road, Upper Montclair, N. J.

This tube is of the high vacuum types with four electrostatic deflection plates, two common, mounted in a glass envelope having a full two inch fluorescent screen. It is $7\frac{5}{8}$ inch overall in length and a large octal base making this tube interchangeable with the 913. From 300 to 600 volts may be used on the second anode. The 24-XH is a practical tube for all routine operations where economy and compactness is essential without sacrificing screen area. List price is \$7.50. The illustration is on next page.

24-XH

TENTATIVE RATING AND CHARACTERISTICS

General Characteristics

Screen Size.....	2	Inches
Overall Length.....	$7\frac{5}{8}$	Inches
Number of Deflection Plates	4	(2 Common)
Base	Large Octal 8-Pin	
Pin 1—Anode No. 2 Plates D_2 and D_4	Pin 5—Control Grid	
Pin 2—Heater and Cathode	Pin 6—Lower Plate D_3	
Pin 3—Anode No. 1	Pin 7—Heater	
Pin 4—Upper Plate D_1	Pin 8—Blank	
Screen	Short Persistent	
Color of Screen.....	Greenish	
Type of Cathode.....	Indirect Heater	

Electrical Characteristics

Heater Voltage (A.C. or D.C.)	6.3 volts
Heater Current6 amperes

Maximum Ratings

High Voltage Electrode (anode No. 2)	600 max. volts
Focus Electrode (anode No. 1).....	300 max. volts
Grid Voltage	Never Positive
Grid Voltage for Current Cut-off	—60 approx. volts
Power Per Sq. Cm. of Screen	10 max. Milliwatts

Typical Operating Conditions

Anode No. 2 Voltage..	400	500	600	Volts
Anode No. 1 Voltage..	80	100	120	Volts
Grid Voltage	Adjusted for Suitable Spot			

HIS PERIODICAL HELPER

I find your magazine very interesting and quite often get numerous ideas from articles, which help me in business. Again, thanks.

GODFREY'S RADIO SERVICE,
184 - 8th Ave., New York City.

Allied Produces New, Scintillating Catalogue

An artistically prepared and splendidly printed 156-page catalogue has just been issued by Allied Radio Corporation,



and splendidly just been issued constituting the Spring and Summer edition. The large front cover is in colors but is reproduced on small scale here with in black and white. One of the outstanding features of the catalogue is its comprehensiveness. For instance, despite compactness, there is a wide and full coverage of the radio field, with offerings attractive

to everybody interested in radio, whether technically or otherwise. There are 53 Knight radio receivers, Knight being the famous trade name of Allied's own products, and these radios include automatic dialing, Touch-o-matic tuning, automatic frequency control and other latest improvements.

There is a listing of 10,000 exact duplicate and replacement parts. Amateurs, experimenters and public address specialists will find a plethora of material catering to their exacting needs. There are portables, phonograph combinations and automobile sets, also P.A. systems from 8 to 60 watts, with latest improvements, besides servicing instruments, kits for construction of various radio devices; generators, Rural power Windchargers, tools.

A copy of the catalogue is obtainable free by addressing Allied Radio Corporation, Dept. 16-E, 833 West Jackson Boulevard, Chicago, Ill.

Supplements Issued Ghirardi Data Book

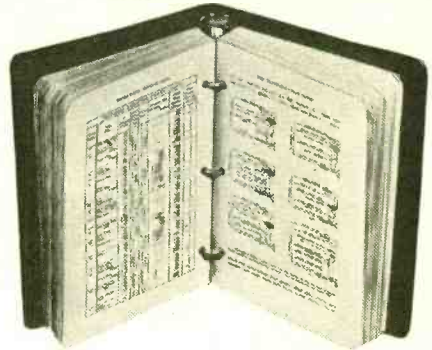

Open view of the Ghirardi field book.

Owners of Ghirardi's "Radio Field Service Data," the 436-page loose-leaf job-data book for radio service men, have already received the first of the two semi-annual Supplements to be issued in 1937. The January Supplement Sheets issued number 32 pages and contain case histories of 112 additional radio receiving sets, giving the actual trouble symptoms and remedies for each set described. The useful Ghirardi Data Book now contains case histories for more than 1,500 American and Canadian receivers, the largest compilation of its kind ever made.

Servicemen who have already purchased the Ghirardi Field Service Data Book are receiving this current issue of Supplement Sheets without charge and will also receive the second set of sheets for 1937 when they are issued in June. Those who now purchase the Data Book will also receive the two Supplements free of charge, until this special offer is withdrawn by the publishers, Radio & Technical Publishing Company, 45 Astor Place, Dept. RW, New York City.

ROAD STILL LOOKS LONG HERE

THINK your magazine improves in nearly every issue. B. F. LEE, Box 293, Leakesville, N. C.

Details of New 2-Inch Cathode-Ray Tube

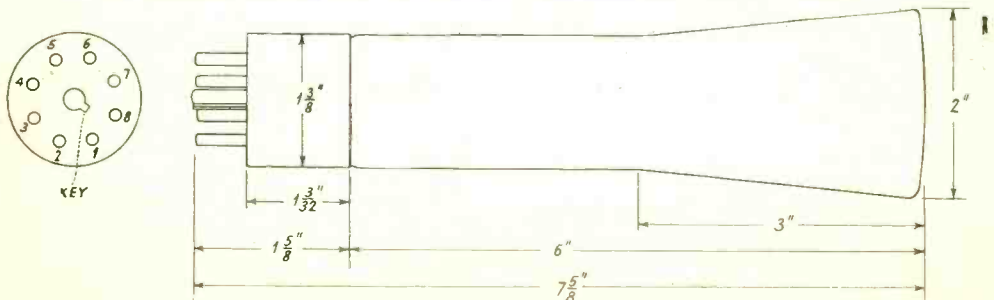

Dimensions and socket connection code (bottom view) of the new 2-inch diameter cathode-ray tube, 24XH. The connections and voltages are the same as for the one-inch diameter tube, the 913.

(Continued from page 56)

of the frequency band, more uniform response is obtained over a greater frequency range than with any single voice coil mechanism. Across the low-frequency section is shunted a capacitor for passing high frequencies. It has been found with this type of mechanism that the high frequencies can be adjusted as desired by placing resistors in series with the low-frequency capacitor. A 5,000-ohm resistor will cut the frequency so that it drops off approximately 5 db. between 2,500 and 5,000 cycles and then will drop quite rapidly so that it is completely off at 7,000 cycles. A 5-ohm resistor placed in series with a shunt capacitor has a tendency to cut the high frequencies from 2,500 to 10,000 cycles approximately 5 to 10 db. and, of course, other values of resistors will cut accordingly.

The front of the loudspeaker opens into a grille mounted in the panel of the cabinet. The rear of the speaker operates into a series of acoustic-filtered chambers arranged in increasing sizes somewhat like an exponential horn. The final chamber opens into another covered grille at the lower section of the cabinet panel and the sound output is obtained from both openings. This design provides an equivalent of an 8-foot baffle. At the same time the usual cavity resonance of cabinet type speaker is eliminated. The cabinet and chambers were originally constructed to arrange and prevent vibration. The back of the speaker being completely sealed makes frequency response independent of location in the room.

There are two models of monitor speakers, less the power amplifier section, available. These are known as MI-4433/4466, operating from 110 volt d-c field supply, unit and MI-4435/4467, operating from 56 volt d-c field supply unit. The voice coil of each system is 15 ohms. Should it be desired to use the amplifier designed for this equipment, it is known as MI-4294. The list price of this amplifier and special base, less the tubes, is \$405; while the list price of the loudspeaker, without amplifier section, is \$133.35, thus making the total cost of the two units \$538.35, f.o.b., Camden, N. J. The amplifier MI-4294 is a bridging type amplifier working from a zero level 500-ohm line. It has a maximum gain of 75 db and has a maximum undistorted output of 20 watts. The frequency response is from 30 to 17,000 cycles. The total distortion arithmetic sum is 5½%. The background level at 45 db. gain is minus 40 db., while the background level at full gain is minus 20 db. The input impedance is 520,000 ohms, with an output impedance of from 7½, 15 and 500 ohms. The volume and control range is 46 db. The output stage utilizes four RCA-283 Radiotrons.

Sparton Parts Catalogue

The Sparks-Withington Company, Jackson, Mich., makers of Sparton Products, announces a 204-page radio parts catalogue. Parts are available for all Sparton models ever produced. A copy is obtainable by addressing J. J. Lynch.

Radolek's New 164-Page Catalogue Just Off Press

The Radolek Co., 601 West Randolph St., Chicago, announces the release of the new Fall and Winter 164-page Profit Guide. This is said to be the most complete, up to the minute catalog of radio replacement parts, supplies, test equipment, tools, late 1937 auto and house radios and 12,000 other items of interest to active radio dealers and servicemen. Everything in radio is here, clearly described, profusely illustrated. Radio servicemen and dealers may obtain a copy by addressing the above company, Dept. RW.



Volume Control Guide Offered Free by IRC

Coinciding with completion of intensive national distribution of the new IRC metallized type volume controls through leading parts jobbers from coast to coast, comes announcement of an IRC Volume Control Guide, by International Resistance Co., 401 North Broad St., Philadelphia, Pa., Dept. RW. It is available free to servicemen and amateurs who request it.

This guide is attractively printed in handy pocket size with durable covers and is punched for convenience in hanging near the user's service bench. It lists in detail the IRC standard controls recommended for leading radio receivers, thus greatly simplifying the job of making quick, accurate replacements.

For convenience of the thousands of servicemen who rely on Rider's Perpetual Trouble-Shooter Manuals for circuit information, etc., the complete IRC Volume Control Replacement Guide has been reprinted in the Index to Rider's Volume 7.

Sylvania Offers Free New Chart, 16x22 Inches

Hygrade Sylvania Corporation, Emporium, Pa., offers free to radio servicemen a revised edition of the Sylvania Characteristic Sheet, containing complete operating characteristics, condensed technical information, and base diagrams for all Sylvania tubes announced up to April 1, 1937. The chart, 16x22 inches, is arranged for use in a standard three-ring binder, or may be opened flat for wall use at the service bench. Address the corporation, Dept. RW, above address.

New M-Y Encyclopedia Is a Feat and a Treat

Differing markedly from anything previously available, the Mallory-Yaxley Radio Service Encyclopedia is a single book designed to place complete service information on more than 12,000 models of radio receivers at the finger-tips of the service man.

The radical advance of the Encyclopedia is that it places all the technical data of a single model receiver in one listing—a listing which not only gives the proper replacement for the volume control, tone control, filter condensers,

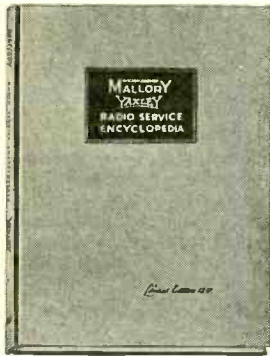

Front of Mallory-Yaxley's most remarkable encyclopedia.

vibrators, vibrator buffer condenser, and electrolytic bypass condensers, but also gives the circuits in which these parts are used. The single listing also gives the intermediate frequency transformer circuit and the types of tubes used.

Despite the thousands of circuit combinations in use, it has been possible to compress all this information into a table of 99 pages.

The standard circuits used as references in the book are complete and cover every hookup in common use. Full technical information is given on the circuit action of each hookup, explaining both how and why in the simplest everyday shop English. The data are so clear and complete that the service man can with complete confidence specify his own replacements when he encounters a newly released model for which service information is unavailable.

Rather than to build up an attitude of awe, the Mallory-Yaxley Radio Service Encyclopedia has completely debunked such subjects as vibrators, power packs, volume control tapers, condenser action and replacements. No attempt has been made to be academic, the important points being hammered home with a frankness that is most unusual in a technical book. The subject of alignment is covered in detail, with much information which has never previously appeared in print. Complete data on automatic frequency control are included together with practical methods of adjusting such receivers. There are nineteen pages of the latest tube

data, seven pages on measurements, including constructional data on a practical bridge and a vacuum-tube voltmeter. Other subjects covered in detail range from antenna design and auto radio interference to voltage doublers.

The Mallory-Yaxley Radio Service Encyclopedia has 224 pages, 8½ x 11 inches, and is profusely illustrated. This book is attractively bound in a stiff washable waterproof cover and is priced at \$2.50 list. This book is sold only by authorized Mallory-Yaxley distributors.

New Tobe Catalogue on Interference Riddance

Specific recommendations for quelling all types of man-made static are given in the current issue of the Tobe Deutschmann Corporation Filterette catalog in which are presented the results of ten years' laboratory and field research by this organization in the radio interference eliminating field.

Forty-two stock models from which may be chosen the correct unit for any application are fully described and their installation illustrated in this handbook for radio servicemen. The Filterettes listed in the catalog are indorsed by leading radio and electrical manufacturers and incorporate the latest improvements so that they may be depended upon to eliminate interference in the shortwave bands as well as in the broadcast band, says Tobe Deutschmann Corporation, Canton Mass.

The catalog also tells how radio servicemen may have placed at their disposal the services of the engineering staff devoted exclusively to the study of radio interference problems.

"Sylvania News" Aged 7; 55,000 Sent Monthly

The March, 1937, issue of Hygrade Sylvania Corporation's "Sylvania News" features the completion of its seventh year of continuous publication. Started in March, 1930, with 3,500 copies, average circulation is now 55,000 copies of each issue. It is mailed free to radio jobbers, salesmen, dealers and servicemen, including many readers in the 119 foreign countries in which Sylvania tubes are distributed.

Started as a small four-page sheet in newspaper tabloid style, format was enlarged until now it has four 13x18-in. pages printed in two colors, with an additional four-page technical section. A chat on radio tube and set trends by Roger M. Wise is a popular feature in each issue. Other Sylvania engineers, as well as outside technicians, frequently contribute articles and data of value to servicemen and radio amateurs. One of the most helpful features is the "Service Exchange." This department is made up entirely from practical hints on radio servicing, contributed by experienced radio

(Continued on following page)

(Continued from preceding page)

servicemen in all parts of the country. At intervals these hints are collected and printed in a "Service Hints Booklet," which is distributed free to servicemen either on direct request to the factory or through Sylvania jobbers. Since the introduction of auto radio, hints relating to this branch of service work have been published in a separate pamphlet, "Auto Radio Installation and Service," also distributed free.

J. M. DeVoe is editor and R. S. Merkle is technical editor.

Hygrade Sylvania Corporation has consistently maintained in "Sylvania News" an editorial policy that stresses assistance in merchandising radio sets and related items, as well as Sylvania tubes and Hygrade lamps. Sales promotion material, dealer helps, window displays, technical literature and equipment are offered to the trade through "Sylvania News," which has proved a very effective medium for distribution of these items through Sylvania jobbers.

A glance through back issues of the publication reveals many highlights in the history of the radio industry. The rapid development and multiplication of radio tube types from the early pentode days to the present is particularly interesting in revealing the rapid strides made by radio in the past seven years.

RECORD SUMMER FORECAST

Radio use this Summer will break all records, according to a survey of the Columbia Broadcasting System prepared by Dr. Daniel Starch. The CBS booklet forecasting the largest regular radio audience states that radio receivers in use will total 34,000,000 with 25,000,000 radio homes equipped, an increase of 2,000,000 more radio families than last summer; that there will be 4,000,000 "extra" or supplementary radio receivers in the twenty-five million radio homes, and that 5,000,000 automobiles will be equipped with radio sets.

Arcturus Hires More Help as Business Booms

The factory of the Arcturus Radio Tube Company, Newark, N. J., is hiring many additional operators in all departments to take care of the great increase in tube sales which the company is experiencing.

"Sales to distributors and set manufacturers, as well as export business," says C. E. Stahl, vice-president and general manager, "are running very substantially ahead of last year. To keep pace with this large increase we have had to add to our factory personnel. Production at this early date in the year is running ahead of the peak months of 1936 and the additional people we are putting on increases our factory employment index."

AT YOUR SERVICE RADIO UNIVERSITY

I INTEND to build a signal generator that for my special purpose must have plenty of hop behind it. The thought came to me that a metal tube could be used, as leakage radiation should be small, due to grounding of the shell. At the same time plenty of ventilation has to be provided, so they say, as the tubes let loose a lot of heat. Please state in what way I shall proceed so that I may obtain the minimum leakage (practically nil), maximum ventilation and enormous hop.—W. R. D.

Evidently what you want from the generator is considerable power, e.g., for use in conjunction with a Q meter circuit. If so, then a beam tube would be just the thing, especially as it makes a fine oscillator. Even the 25L6 has a mutual conductance of 8,000 micromhos, and the Gm is the figure of merit for an oscillator. However, when you ask how the circuit can be completely shielded in a necessarily ventilated box, you put quite a poser. The metal shell will not act as a total shield for the purpose in mind, and there will be radiation from it, particularly near the top. The box may be of the louvred type, while inside the whole works would be additionally screen-enclosed. But there will be some leakage nevertheless. Practically nothing is "grounded" in such a circuit as you propose, and this is nearly true of all peppy oscillators, even those that merely have a high oscillating voltage, and deliver hardly any power.

* * *

GLASS OCTAL TUBE, 6U7G

WHAT glass tube with an octal base has characteristics similar to the 6D6 super-control amplifier?—U. H.

The 6U7G fulfills your requirement. The capacities are small, e.g., grid to plate is .007 mmfd. maximum, grid to cathode is 5.2 mmfd. and plate to cathode is 6.8 mmfd. This is about half the output capacity of receiver tubes in general.

* * *

SERIES HEATERS

PLEASE recommend the heater connections for a four-tube t-r-f set, using series 6C6, 6D6, 25Z5 and 43. Include a pilot.—L. M.

Connections may be made as shown, with 1-2 a ballast on the line cord, 2-3 a 20-ohm wire resistor across which is a 6.3-volt pilot. Either the power tube (as shown) or the rectifier comes next, then the other 25-volt type, the rest as shown.

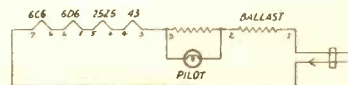

A four-tube universal set, with 6C6 detector, has one side of 6C6 heater connected to the line.

New Metal Tube, 5T4, Is 250 Ma Rectifier

A new all-metal full-wave rectifier designated as 5T4 was recently announced to radio equipment manufacturers.

The 5T4 is similar electrically to the glass type 5Z3 except for a lower filament-current rating. This new tube is intended for supplying rectified power to radio equipment having very large direct-current requirements.

5T4

Full-Wave High-Vacuum Rectifier (Tentative Data)

Filament Voltage (A.C.)	5.0 volts
Filament Current	2.0 amperes
Maximum Overall Length	4 1/4-in.
Maximum diameter	1-23/32-in.
Base	Large Wafer Octal 5-Pin

As Full-Wave Rectifier

Condenser-Input to Filter

A-C Plate Voltage Per Plate (RMS)	450 max. volts
Peak Inverse Voltage	1250 max. volts
D-C Output Current	250 max. milliamperes

CHOKE-INPUT FILTER

Filament Voltage (A.C. or D.C.)	5	Volts
A-C Plate Voltage per Plate (RMS)	550 max.*	Volts
Peak Inverse Voltage	1550 max.*	Volts
D-C Output Current	250 max.*	Ma.

*Permissible only with filter circuit having an input choke inductance of at least 10 henries.
[Data supplied by RCA Manufacturing Company]

New Economy Tube Announced by Triad



H. H. Steinle, director of sales, Triad Manufacturing Co., Pawtucket, R. I., is releasing Triad's Technical Bulletin No. 109, describing the new 25A7G.

"Where it is desired to get out a very compact a.c.-d.c. receiver, with reasonably good power output, the 25A7G should fill the bill," he said.

"It is essentially the same type of tube as the 12A7, which has been on the market for several years, but both the rectifier and the output pentode sections have been stepped up to deliver greater power output.

"The design of this tube is extremely conservative and rugged, to withstand normal abuse."

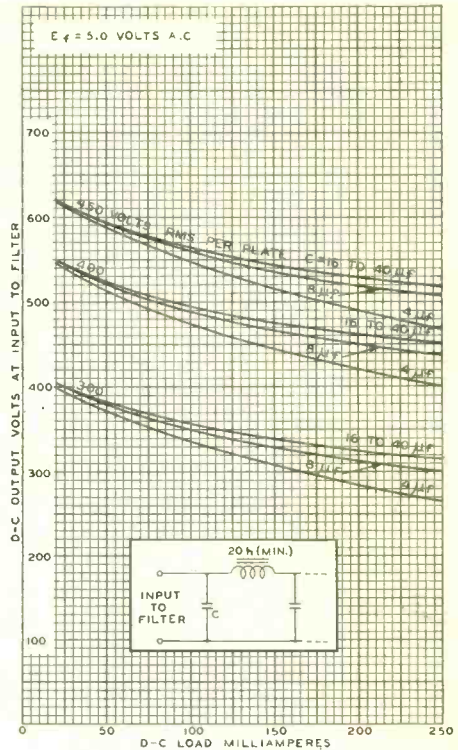

Regulator curve of the 5T4.

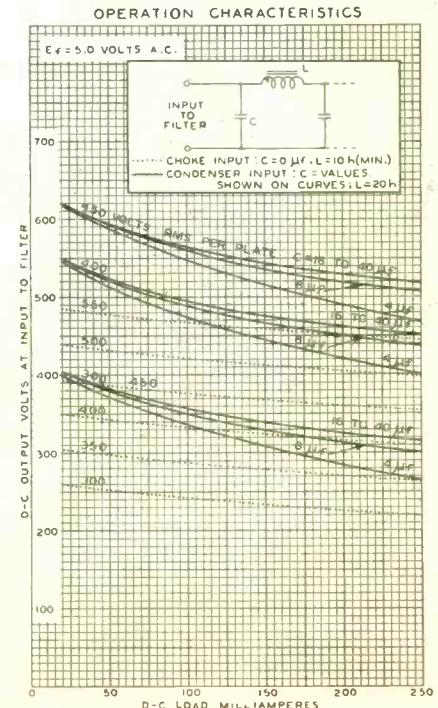

Choke input and condenser input compared.

MIDWEST..

**FACTORY-TO-YOU
SAVES 50%**

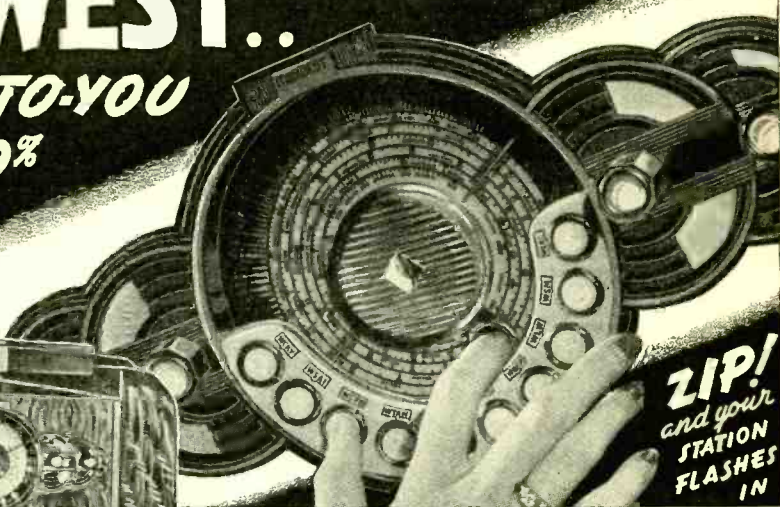
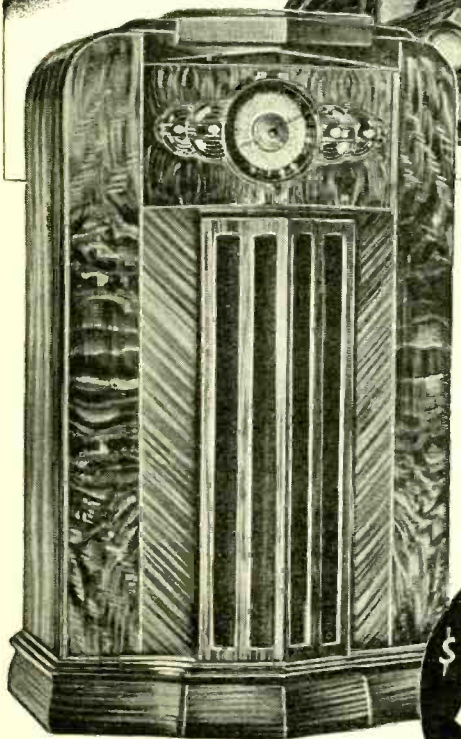

**ZIP!
and your
STATION
FLASHES
IN**

HALF the Cost... TWICE the Performance
14 TUBES FOR THE PRICE OF 8

This great new Midwest has caught the nation's fancy, because scores of marvelous new features like Dial-A-Matic Tuning*, Elektrik-Saver* (optional*) give magnificent world-wide reception and glorious crystal clear realism. America OK's Midwest radios because they out-perform ordinary sets on a point-for-point comparison. Not a cut-price set, but a more powerful super performing radio in a big, exquisitely designed cabinet

of matched walnut! You are triply protected with Foreign Reception Guarantee . . . One-Year Warranty and Money-Back Guarantee. Now, you can roam the world in a flash . . . switching instantly from American programs to police, amateur, commercial, airplane and ship broadcasts . . . to the most fascinating foreign programs. When you buy the Midwest factory-to-you way, you deal directly with the factory that makes radios—instead of paying extra profits to wholesalers, distributors, retailers, etc.

Only
\$39.95
AND UP
NEW LOW BASE PRICE*
FOR A WORLD-WIDE
MIDWEST

30 DAYS FREE TRIAL!

For seventeen years, Midwest engineers have pioneered many features and advantages which others quickly copied. The new 1937 Midwest is designed years in advance. It has everything! Not just two or three outstanding features, but scores of new developments...many of them exclusive. Send for the FREE 40-page book. See for yourself that Midwest offers today's greatest radio values. See why so many say: "Midwest sets the pace!"



Midwest engineers discussing new chassis

*Other Midwest radios complete with tubes and console, \$29.95 and up! (*Base price, less tubes and console.)*

Send for **FREE 40-PAGE CATALOG!**

Remember! Nothing of value is added to a radio just because it is handled many times. You have a year to pay . . . terms as low as 10c a day . . . you secure the privilege of 30 days FREE trial in your own home.

ZIP!... and Your Station Flashes In!

Your radio enjoyment is doubled with Dial-A-Matic Tuning, the amazing new Midwest feature that makes this radio practically tune itself. Zip!... Zip!... Zip!... Stations come in instantly, automatically, perfectly . . . as fast as you can push buttons.



PASTE COUPON ON 1¢ POSTCARD...OR WRITE TODAY!

MIDWEST RADIO CORPORATION
Dept. RW 6 Cincinnati, O.
Send me your new FREE catalog and complete details of your liberal 30-day FREE trial offer.
(Special offer and prices prevail only when dealing direct with factory by mail.)

Name.....
Address.....
Town..... State.....
User-Agents Make Easy Extra Money Check Here for details.

MIDWEST RADIO CORP.

DEPT. [R.W. 6]
Established 1920

CINCINNATI, OHIO, U.S.A.
Cable Address MIRACO...All Codes

Expertly Selected Radio Books

Best Calculated to Advance Your Knowledge and Expedite Your Operative Technique



Undisputed Leader of All Radio Service Books

Alfred A. Ghirardi's "Modern Radio Servicing" is the standard book in the field. It contains everything you need to know about radio servicing as it is practiced today by the most successful organizations in the country. All about test instruments, their theory, operation and construction, complete with circuit diagrams. All the latest test and repair methods and trouble-shooting short-cuts. All the most successful repair methods. Big sections on noise and interference "spotting" and elimination in broadcast and all-wave sets; on aligning receivers (including cathode-ray method); AVC and QAVC circuits; auto radio; sales and advertising; etc. More than 1,300 pages. 749 illustrations. Order Cat. MRS, postpaid, \$4.00.

Ghirardi's "Radio Field Service Data," new edition, has more than 400 pages of practical "bench data"—twice as much as the first edition. I.F. peaks for 5,226 superhets, including 1937 models. "Case Histories" for over 1,500 receivers, giving actual trouble symptoms and remedies for each one. Ignition system data, interference remedies, and electrical wiring diagrams for all cars. Latest data on glass and metal tubes. In all, more than 70 different charts, diagrams and tables arranged in handy form for quick reference. Now in loose-leaf form, it is easily kept up to date with the Supplements issued every January and June. Order Cat. RFS, postpaid, \$2.50 (includes supplements for one year).

Combination price of \$6 gives you both these indispensable servicing books, together with one year's supplements to the Data Book. Order Cat. COMRFS.

Other Top Selections

"THE INDUCTANCE AUTHORITY," by Edward M. Shiepe. Enables winding radio-frequency solenoids to 1% accuracy without computation. Order Cat. INA @ \$2.00, postpaid. Price includes 18x27" inductance-capacity-frequency chart as supplement.

"MEASUREMENTS IN RADIO ENGINEERING," by Frederick Emmons Terman, revealing the measurement equipment and technique, from the pen of a great authority. 400 pages, 6x9, 208 illustrations. Order Cat. TMRE, postpaid, \$4.00.

"PRACTICAL RADIO COMMUNICATION," by Arthur R. Nilson and J. L. Hornung, a complete instruction course and reference guide in radio station operation. Principles, systems, equipment, operation (including short and ultra waves), 754 pages, 6x9; 435 illustrations; flexible cover. Order NHPRC, postpaid, \$5.00.

The Handiest Handbook of All!

A handbook is handy when it "has what it takes," is expertly referenced, and quickly provides authoritative solutions. This Keith Henney's "Radio Engineering Handbook" certainly does. It's a great book for engineer or experimenter. Really

24 reference books under one cover. 850 pages, 4 1/2 x 7, fully illustrated. Flexible cover. Order Cat. HREH, postpaid, @ \$5.00. New edition.

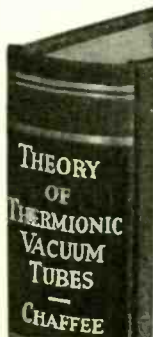

The Tube Authority

A fundamental treatise, comprehensive and authoritative. "Theory of Thermionic Vacuum Tubes," by E. Leon Chaffee, Professor of Physics, Harvard University, covers the field. A knowledge of algebra and some calculus are necessary for full appreciation of the contents. Treatment is mathematical. 652 pages, 6x9; 357 illustrations. Order Cat. CTTVT, postpaid, @ \$6.00.

Any or All of Above Books Sold on Five-Day Money-Back Guarantee!
BOOK DEPARTMENT, RADIO WORLD, 145 W. 45th ST., N. Y. C.

CLASSIFIED ADVERTISEMENTS

7 cents a word. \$1.00 minimum.

3 BIG VALUES—No. 1—Including: Magnificent fully complete, new first issue of Italian Abyssinia; Yugoslavia Commemoratives of the Holy King, complete set; attractive Portuguese Colonials; Austria Commemoratives; Russia, etc. The Collection of 336 stamps for net \$1.25.

No. 2—including: Superb 18th Century complete Memorial set of the Kings of Montenegro Mausoleum; scarce old Turkey, Sierra Leone, Newfoundland, South Africa, India, Egypt, Gold Coast, Charkhari, Southern Rhodesia, transvaal, Philippines; choice Pictorial of the French Colonies. The Collection of 475 stamps for net \$1.25.

No. 3—including: Beautiful new Vatican Commemoratives of the Catholic Press World Exhibition; Georgia and Bosnia complete sets; attractive and scarce Italian Commemoratives; Radio Congress, Virgil, Holy Year, Royal Naval Academy, etc.; San Marino, Costa Rica, Spain Airmails and Commemoratives; fascinating Gold and Silver complete Coronation set of Persia. The Collection of 387 stamps for net \$1.50.

The above THREE complete collections, totalling 1,218 all-different, genuine stamps, with a considerable catalogue value, instead of \$4—for ONLY \$2—to Approval Applicants. **PARAGUAY PHILATELY COMPANY**, Asuncion—Villa Morra—(Paraguay, South America), The House of Confidence.

AMATEUR CARTOONISTS—Win \$25.00. No drawing ability necessary to win. 26 prizes in all. Rush name on postcard for valuable tips on "How To Make Money With Simple Cartoons," cash prize entry blank and rules. Send no money. Cartoonists' Exchange, Dept. C-1456, Pleasant Hill, Ohio.

RADIO WORLD AND POPULAR MECHANICS MAGAZINE—Radio World is \$2.50 a year, and Popular Mechanics Magazine is \$2.50 a year. Popular Mechanics Magazine does not cut rates, but Radio World will send both publications to you for one year for \$3.75. **RADIO WORLD**, 145 West 45th Street, New York City.

HAVE YOU BACK NUMBERS of Radio World, for May, August, 1935, or June, October, 1936? If so, please communicate with Radio World, 145 West 45th St., New York, N. Y.

FOR SALE COMPLETE RTI COURSE. Write for details and price. **BEITMAN**, 3727 West 13th, Chicago.

AMATEUR RADIO, Commercial Radiotelephone and Radiotelegraph licenses, complete training, resident and correspondence courses. Every graduate a licensed operator. **NEW YORK WIRELESS SCHOOL**, 1123 Broadway, New York.

A COMBINATION OFFER! RADIO WORLD and "RADIO NEWS"

\$3.50

Canadian and Foreign, \$1.50 extra on this offer.

You can obtain the two leading radio technical magazines that cater to experimenters, service men and students, for one year each, at a saving of \$1.50. The regular mail subscription rate for **RADIO WORLD** for one year is \$2.50. Send in \$1.00 extra, get "Radio News" also for a year—a new issue each month for twelve months. Total 24 issues for \$3.50 and \$5.00 to foreign countries.

RADIO WORLD, 145 West 45th Street, N. Y. City

MAILING LISTS

775 Teachers of Radio and Electrical Engineering in 130 Engineering Colleges throughout the country.

Price \$10.00

Send for our general catalog outlining Mailing Lists of all types of Schools, Teachers, Students, School Executives, etc., we can supply, including a detailed Statistical Chart of the Educational Field by States.

Educational Lists Co., Inc.

110 West 40th St.
New York City

612 N. Michigan Ave.
Chicago, Ill.

The Remedy for... ANNOYING COIL PROBLEMS!

WINDING solenoid coils for radio frequencies requires knowledge of the number of turns of any selected type of wire on any sensible diameter to attain an inductance suitable for the tuning condenser and lowest frequency. Hence, with capacity and frequency known, there are two unknowns: (1), the required inductance; (2), the number of turns to establish that inductance. The answers are obtained without computation by use of "The Inductance Authority," by Edward M. Shiepe, and an 18 x 20" supplement. On the large supplement are plotted the "curves" of frequency, capacity and inductance in straight lines, so for a desired low frequency and known capacity the unknown inductance is solved by mere inspection. The number of turns for attainment of that inductance, for all popular tubing diameters and all generally used wire diameters and wire insulations, is read from the inductance-turns charts which are in the bound volume. Coil and set manufacturers, as well as home and shop experimenters, students and teachers freely use this book. Accuracy is 1%. The only book of its kind in the world.

Order Cat. **INA** (price includes bound volume and supplement) postpaid anywhere on earth **\$2.00**

Or send \$5.00 for a two-year subscription for **RADIO WORLD**, regular rate, and this valuable book and supplement will be sent **FREE** and postpaid. Order Cat. **PR-IAC**.

RADIO WORLD

145 West 45th Street, New York City

METAL CHASSIS

We can supply chassis for any make receiver, experimental or otherwise.

Inquiries should be accompanied with sketch and complete details enabling us to give quick service as to prices and delivery.

KORROL MFG. CO., Inc.

232 Greenwich St. Dept. RW.-637 N. Y. City

National Radio Products

Descriptive price list Bulletin No. 261

If you are without a copy of the new National General Catalog, write us and we will gladly send you one. Or better, visit your dealer. He will welcome the opportunity to give you a copy of this new catalog and to demonstrate the latest National products.

NATIONAL CO., INC., MALDEN, MASS.

BLAN

THE RADIO MAN, INC.

Now in our new building at

64 DEY STREET, NEW YORK CITY

Just a block from the old location at 177 Greenwich St.

Since 1923, we have been catering to the needs of Radio and Electrical Experimenters. From cat-whisker to television tubes, miniature motors, relays from 29c to \$6.50—photoelectric cells, neon lamps from 15c to \$1.50, in fact anything and everything you may need in stock or know where to obtain for you. We have been shopping agents for well-known schools and institutions for many years, why not for you?

Whenever you think of anything electrical, remember, "YOU CAN GET IT AT BLANS!"

SPECIAL 2-FOR-1 OFFER RADIO WORLD

THE HOW-TO-MAKE-IT MAGAZINE
In Its New Monthly Form

Radio World is \$2.50 a year (12 issues), 25c. per copy. Canada and foreign, \$3.00 yearly. Offers of Radio World and other worthwhile publications for one full year on each (NET):

- RADIO WORLD and SHORT-WAVE and TELEVISION, \$3.50.
- RADIO WORLD and POPULAR SCIENCE MONTHLY, \$3.50.
- RADIO WORLD and RADIO, (Los Angeles), \$3.50.
- RADIO WORLD and RADIO-CRAFT (12 issues), \$3.50.
- RADIO WORLD and RADIO INDEX (monthly, 10 issues), stations, programs, etc., \$3.50.
- RADIO WORLD and SERVICE (monthly), \$3.50.
- RADIO WORLD and EVERYDAY SCIENCE AND MECHANICS (monthly), \$3.50.
- RADIO WORLD and BOYS' LIFE (monthly, 12 issues), \$3.50.
- RADIO WORLD and TRUE STORY (monthly), \$3.00.
- RADIO WORLD and LIBERTY (weekly), \$3.00, U. S. only.

Select any one of these magazines and get for an entire year by sending in a year's subscription for RADIO WORLD at the regular price, \$2.50, plus a small additional amount, per quotations above. (Add \$1.50 for extra foreign or Canadian postage for both publications.)

Name

Address

City and State.....

- If renewing an existing or expiring subscription for RADIO WORLD, put cross in square.
- If renewing an existing or expiring subscription for other magazines, put cross in square.

Special Trial Offer for Radio World only: \$1.00 for 5 months, postpaid. Mail order with remittance to Radio World Office. NET.

RADIO WORLD, 145 W. 45th St., New York

TELEVISION

"TELEVISION WITH CATHODE RAYS," by Arthur H. Halloran. Farnsworth and Zworykin systems fully explained. The treatment is mathematical. It is a book for the well-grounded radio man who has vision, the man who wants to be among the first to cash in when the pictures go on the air commercially, but is not for novices. 100 pages or more of supplementary data. Price \$2.75 post-paid (including Supplements).

RADIO WORLD

145 West 45th Street, New York City, N. Y.

the Most Complete Radio BUYING GUIDE FREE!

Everything in Radio

The completely revised Summer and Early Fall edition of the 1937 Radolek Profit Guide is just off the press. Over 1000 NEW ITEMS . . . plus an ADVANCE SHOWING OF 1938 RECEIVER MODELS.

164 Pages of valuable, detailed radio buying information . . . contains the most complete replacement parts listings of volume controls, condensers, transformers and vibrators. OVER 12,000 REPAIR PARTS — THE RIGHT REPLACEMENT ITEMS FOR EVERY RADIO THAT YOU WILL SERVICE. Radolek specializes in giving the radio-man what he wants, when he wants it, and at the right prices. Send for your Profit Guide NOW!

RADOLEK

601 W. RANDOLPH, CHICAGO, DEPT G-7
Send me the Radolek Radio Profit Guide FREE.

NAME

ADDRESS

Service man? Dealer? Experimenter?

Five New Glass Tubes

Five new glass-bulb types of radio tubes having 6.3-volt, 150-milliamperere heaters are announced by RCA Radiotron as follows:

6D8-G, pentagrid converter, similar to the 6A8-G and 6A8.

6L5-G, detector amplifier triode, similar to the 6C5-G and 6C5.

6N5, electron-ray tube (indicator type), similar to the 6G5.

6S7-G, triple-grid super-control amplifier, similar to the 6K7- Gand 6K7.

6T7-G, duplex-diode high-mu triode, similar to the 6Q7-G and 6Q7.



RADIO SERVICING SHORT-CUTS and Money Making Ideas

A completely new and different book tells how radios may be repaired quickly with the absolute minimum of test equipment. Proves that by an actual test 9 out of 10 radios can be fixed with simple tools and volt-ohmmeter. The author, M. N. Beitman, for years in the servicing profession, realized and kept data on these facts. Page after page of practical information. Many real money-making ideas and hints applicable to all sets.

Principles of

PUBLIC ADDRESS SYSTEMS

The only practical handbook on P. A. Covers in detail everything about Sound, from various microphones to loudspeaker placement. Many examples and circuit diagrams.

MATHEMATICS OF RADIO SERVICING

Introduces and explains the use of arithmetic and elementary algebra in connection with problems found in radio servicing. Numerous examples taken from actual radio cases. Plainly written and easy to understand. Size: 8 1/2 x 11 in.

PRICE 50c EACH

SUPREME PUBLICATIONS

3727 West 13th St., Chicago, Illinois

Elgin Institute Presents . . .

800 Tube Tester

Tests all types, including the new metal tubes. Direct reading scale is colored "Good" and "Bad." Tests individual sections of diode and triode tubes. It is easy to use with a new and simple circuit approved by leading engineers. Employs a new improved type emission circuit. It is positively the finest, most accurate low priced tube tester ever offered. Net price.....



\$11.50

801-Volt-Ohmmeter

A sensationally low priced instrument that will prove itself to be the busiest meter in your shop. Its accuracy plus its compactness makes its indispensable to the servicemen for general test purposes. Test 0/5/50/500/1000 volts D.C. Resistor tests from 0 to 500,000 ohms are obtainable. Net \$5.75 price



A.C.-D.C. Model

Similar to above but tests A.C. voltage and 0-75/50/500 D.C. mill. ranges. Net price

\$12.50

TRY-MO RADIO CO, INC.

85 Cortlandt St.

New York City

MAILING LISTS

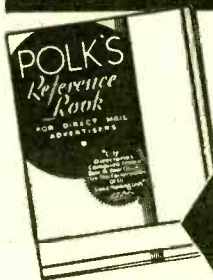

GET OUR FREE REFERENCE BOOK and MAILING LIST CATALOG

FREE

Gives counts and prices on accurate guaranteed mailing lists of all classes of business enterprises in the U. S. Wholesalers—Retailers—Manufacturers by classification and state. Also hundreds of selections of individuals such as professional men, auto owners, income lists, etc.

Write today for your copy

R. L. POLK & CO.

Polk Bldg.—Detroit, Mich.

Branches in Principal Cities

World's Largest City Directory Publishers Mailing List Compilers. Business Statistics. Producers of Direct Mail Advertising.

AMATEURS! Get ALLIED'S New Spring CATALOG!



Send for the new Spring 1937 ALLIED Radio Catalog! 156 pages packed with Everything in Radio at lowest prices; more than 10,000 exact duplicate and replacement parts; latest Amateur transmitters, receivers and transceivers; dozens of set-builders' kits; 53 new Knight Radios; test instruments; P. A.; books, tools, etc.—Radio's Complete Supply Guide!

ALLIED RADIO CORP. Dept. 16F 833 W. Jackson Blvd., Chicago, Ill.

Send me Your Free New 1937 ALLIED Catalog.

Name

Address

Free

IN OSCILLATORS IT'S ACCURACY!



MODEL 557 \$ **18⁰⁰**-

RANGER
EXAMINER

TRIMMER

**EXCLUSIVE RANGER-
EXAMINER
DEVELOPMENT**

This amazing accuracy has been made possible by an exclusive Ranger-Examiner development. Each individual coil is separately calibrated by an exclusive method of peaking with trimmer condensers.

Model 557 All-Wave Direct Reading Signal Generator uses plug-in type coils. Five frequency bands are covered from 110 to 20,000 K.C., all fundamentals. Completely shielded for static and magnetic fields. Attenuation and stability are outstanding features. Strong signals both modulated and unmodulated are furnished.

Supplied in attractive Black Leatherette Case. Silver and Black Panel.

DEALER PRICE \$18.00

Guarantees You

- 1% ACCURACY TO 3,000 K.C.
- 2% FOR HIGHER FREQUENCIES
- RANGE 110 TO 20,000 K.C.

RANGER
EXAMINER

READRITE METER WORKS
627 College Dr., Bluffton, Ohio

Without obligation please send me more information on Model 557. I am also interested in.....

Name

Address

City State

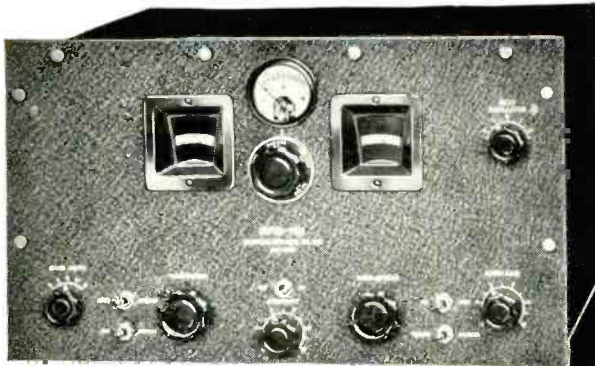

★ At Left—New "SUPER-PRO" in Metal Cabinet.

Below—Rugged New "SUPER-PRO" Tuning Unit.

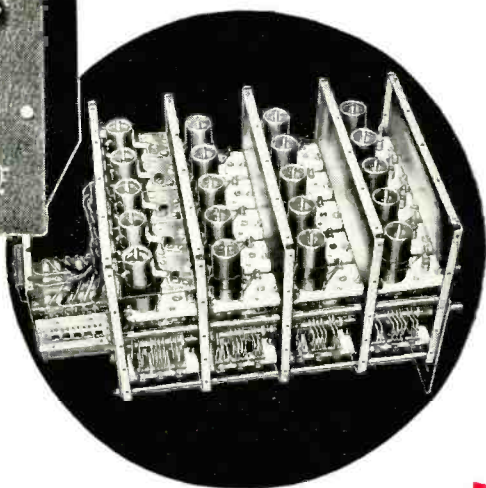

THE Perfect RECEIVER FOR 10 METERS!

EXHAUSTIVE field and laboratory tests made by countless critical amateurs, engineers, and professional operators now using the new "Super-Pro" continue to conclusively prove that "Super-Pro" performance on 10 meters is truly outstanding!

One of the features responsible for this high efficiency is the two stage R.F. amplification system used on the 20-40 mc. band, as well as the other four bands in this receiver. This affords a sensitivity of 0.8 microvolt (30% modulated) with a signal to noise ratio of 6 to 1 at 28 megacycles! This system also affords an image rejection ratio so high as to provide complete freedom from "two-spot" tuning except in exceedingly rare instances, viz.—at 28 mc. the ratio is 150 to 1; at 14 mc.—1900 to 1; at 7 mc.—10,000 to 1, etc.

The A.V.C. action of the new "Super-Pro" has been developed to an unusually high degree of efficiency—a change of 33,000 to 1 in signal input causing a change of only 2 to 1 in the output! The "Super-Pro" electrical band spread system provides a spread of over 90 divisions on the 28 to 30 mc. band.

Other popular bands are similarly spread for easy tuning.

All "Super-Pro" receivers employ direct tuning with calibrations held to within a tolerance of plus or minus 1/2%. The tuning range of the 10 meter model is from 1.25 to 40 mc. in five bands. A model for the .54 to 20 mc. range with identical features is also available.

There are a host of other outstanding features in the new "Super-Pro" models such as—calibrated band width, beat oscillator, audio and sensitivity controls; stand-by switch; relay terminal strip; 8 metal and 8 glass tubes; separate humless power supply, trouble-free cam switch, etc. Crystal or standard models are available for table mounting or rack mounting.

MAIL COUPON FOR FURTHER DETAILS!

HAMMARLUND MFG. CO., INC.
424-433 W. 33rd St., N. Y. City

- Please send me new "Super-Pro" bulletin.
- Please send me new '37" catalog.

Name
Address
City State

RW-6



★ Send for this bulletin!



HAMMARLUND